



Residential

Liftstation

Installation

MOA Style
Using a Greer Poly Tank

 **Anchorage Tank**

INTRODUCTION

This manual is a guide to the operation and maintenance of your Septic Tank, Effluent Pumping (S.T.E.P.) system.

While many homeowners are capable of and occasionally install gravity septic systems, the installation of the S.T.E.P. system is considered by Anchorage Tank to be the province of a professional. We provide assistance to *contractors* to assure the homeowner of proper installation. Due to our time constraints, we are unable to render *installation* assistance on those systems not so installed.

Your Installer is: _____

The Telephone Number is: _____

Your installer has provided you with the best equipment of its kind available today. It is a professionally designed unit manufactured by, and originally purchased from Anchorage Tank, 2723 Rampart Drive, Anchorage, Alaska 99501, telephone (907) 272-3543.

The S.T.E.P. tank is equipped with a patented pumping system designed and manufactured by Orenco Systems, Inc. 814 Airway Avenue, Sutherlin, OR 97479-9012, telephone (541) 459-4449. In the event you have any questions about or any problems with your S.T.E.P. system, please carefully review this manual paying particular attention to the trouble shooting guide. If your difficulties persist, a call to Anchorage Tank can usually clear things up.



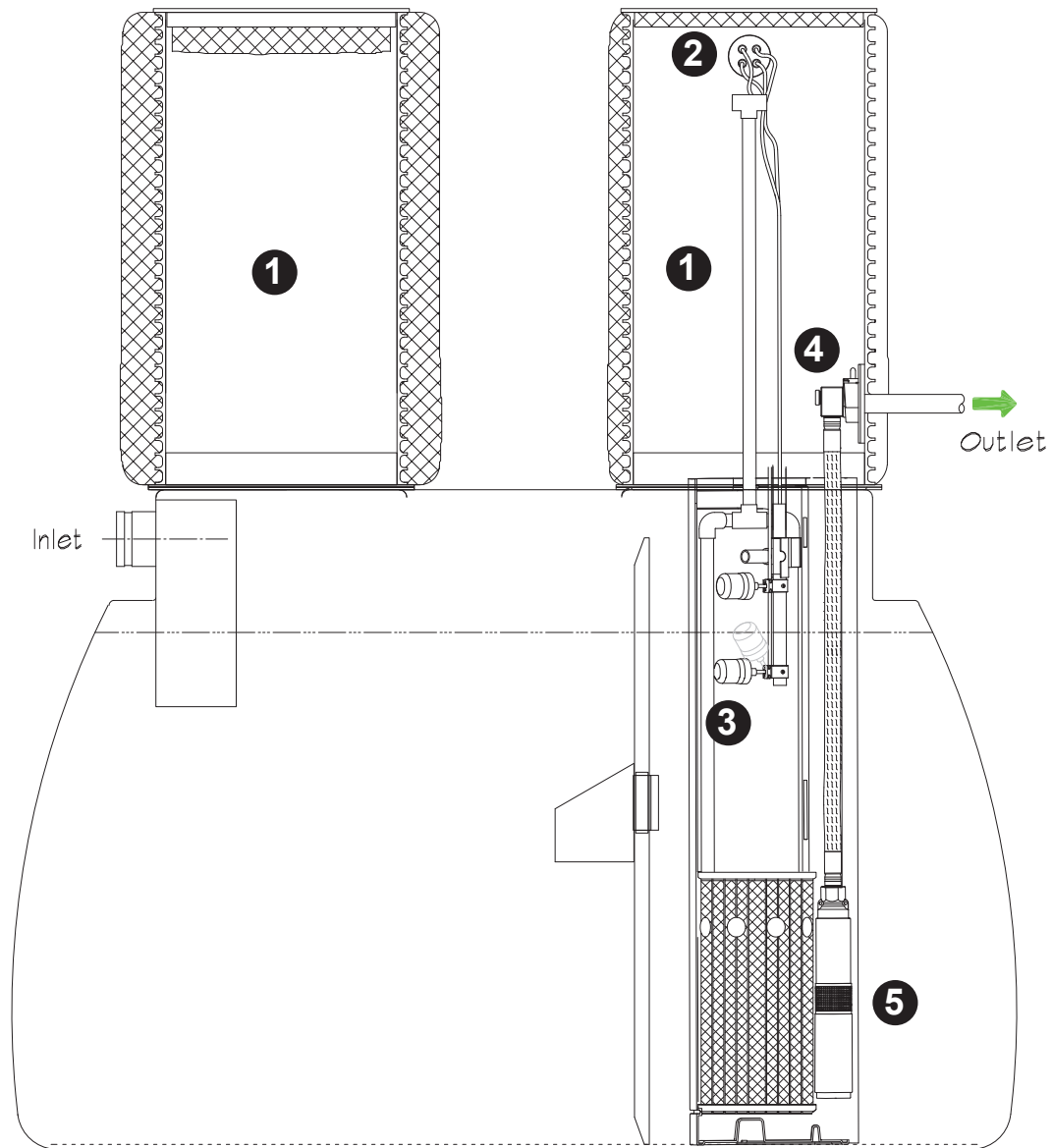

Septic Tank, Effluent Pumping (S.T.E.P.) System

The Anchorage Tank S.T.E.P. System (also called a Lift Station) is a combination of a specially designed Greer Tank Poly septic tank and Orenco Systems, Inc. riser, pumps, floats, and controls.

The S.T.E.P. system works the same as a septic tank, except the effluent is pumped to a drainfield instead of flowing there by gravity.

Designed specially for tough Alaskan conditions, the S.T.E.P. System is available with either single or duplex pumps, in residential and commercial configurations. This book illustrates the installation of a residential liftstation using a Greer Tank poly tank.

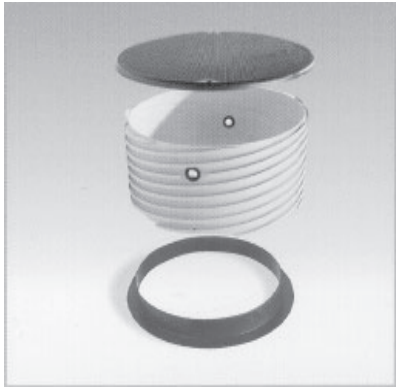

1 Riser, Lid, and Accessories

- Allow easy access to tank
- Attractive, non-skid lids
- Strong & lightweight
- Insulated with 2" or 4" foam
- Standard 48" length
- Longer risers available in cut-to-length increments
- Tamper resistant



2 External Splice Box

- UL listed
- At-grade installation
- Strong & lightweight
- Completely watertight
- Provides easy access for inspection and servicing
- Covered by U.S. Patent numbers D461,870 & D445,476

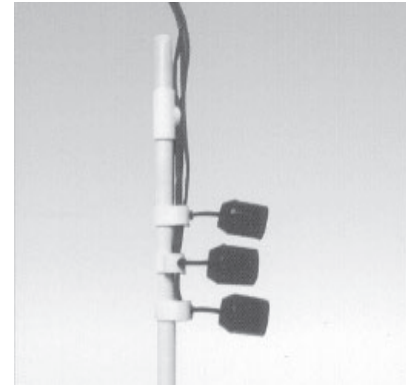

3 Float Switch Assembly

- For reliable pump control
- Signal and motor-rated switches
- Arrangements for any pumping situation

Your float switch assembly will have only 2 floats.

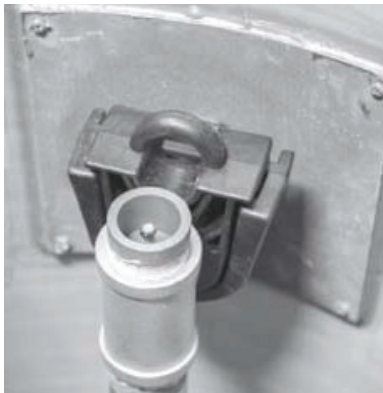

4 Hanging Discharge Assembly

- Fiberglass mounting plate with a quick-disconnect fitting and flexible, high-pressure hose with stainless steel fittings
- Provides clear access for maintenance and servicing of the pump system
- Configurations available for deep installations and designed for Alaskan conditions



5 Effluent Pump

- Turbine-type effluent pump manufactured specifically for wastewater applications. UL listed
- Lightweight (about 25 pounds) yet powerful
- High pressure capacity to clear plugged orifices.
- Extremely durable and versatile



Control Panel

- UL listed
- Engineered specifically for wastewater applications
- Corrosion-proof NEMA 4X rated enclosures
- Models for any need

Residential Liftstation Manual

DRAWING NO. 1 LIFT STATION COMPONENTS

(TANK NOT SHOWN)

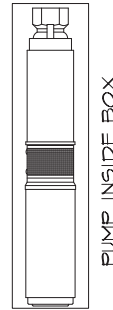
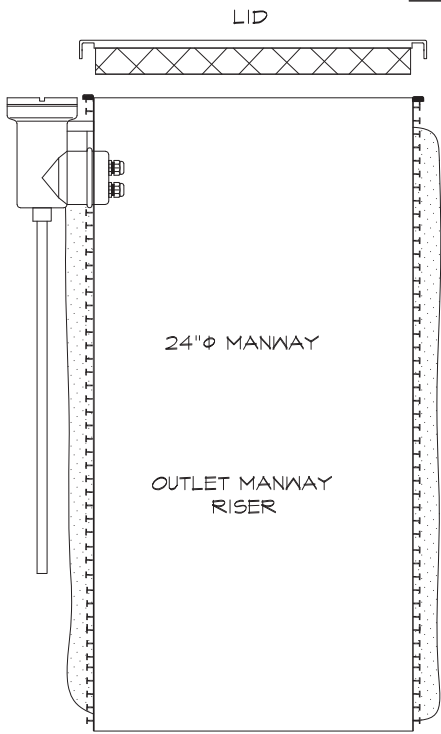

Control Panel



Sentinel 1
Remote Alarm

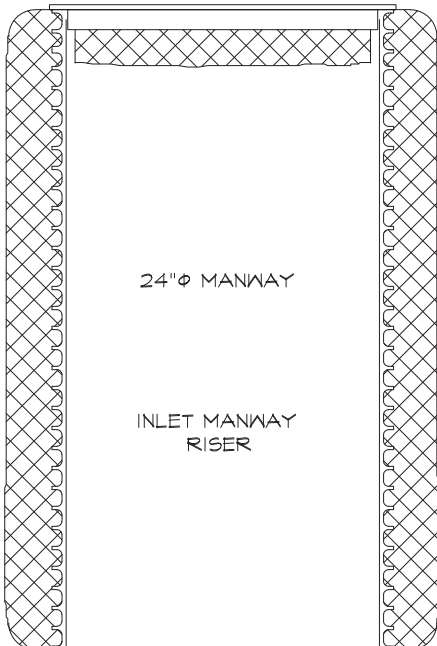

MA320
METHACRYLATE
ADHESIVE

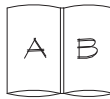

MA320
METHACRYLATE
ADHESIVE



1-1/4" FLEX CONNECTOR
(SLIP X SLIP)



HANGING
DISCHARGE
ASSEMBLY

MA320
METHACRYLATE
ADHESIVE



RETRIEVAL
ROPE

FLOAT SWITCH
ASSEMBLY

BIOTUBE
FILTER

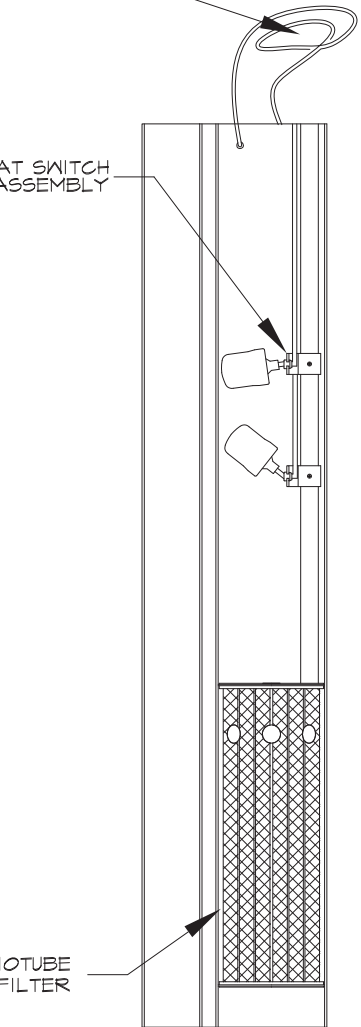

COMPONENTS

Please take a moment here to review the drawings of the S.T.E.P. components, shown in drawing #1, on the facing page. The components include:

1. THE TANK.

Although not shown with the components, your tank is a specialized unit modified specifically for the S.T.E.P. system. It is not a standard septic tank. It is factory tested for water tightness. The tank features two insulated risers for pumping out the front compartment and pump vault access.

2. THE UNIVERSAL BIOTUBE PUMP VAULT.

This screened vault, is constructed of durable polyethylene plastic, because plastic is not affected by the caustic environment of your septic tank. The screened vault is the heart of your system. It is your primary insurance against drainfield failure due to clogging from particulate matter and grease. It must be maintained on a regular basis. See the maintenance section for instructions. This vault contains:

- a.) a flow inducer, in which the pump(s) is placed;
- b.) an adjustable float holder for the level control float switches;
- c.) a check valve for draining when the vault is pulled for maintenance;
- d.) a nylon retrieval rope;
- e.) Orenco Systems® Biotube® effluent filter;
- f.) the pump is a 1/2 horsepower submersible turbine pump especially designed and Underwriters Laboratories listed as an effluent pump. In the event that it ever needs to be replaced, it must be replaced by exactly the same type pump, which is available only from Anchorage Tank or Orenco Systems. A similar looking well-water pump is unlisted for and is *not* designed to be used in septic effluent and may fail prematurely. The only internal piping and fittings are the pre-fabricated hanging discharge assembly.

3. THE ELECTRICAL CONTROL/ALARM PANEL.

The electrical control/alarm box is weatherproof, and designed to be mounted outside the house within view of the septic tank. The electrical controls inside the box are activated by float switches in the tank. Since this control panel is mounted outside, the Municipality of Anchorage requires a remote alarm mounted indoors as well. This alarm is fed through telephone wire from a relay in the main electrical control box. Inside the control box are the main circuit breaker (gray), the alarm circuitry, and the terminal strip where the connections to the house power and the tank are made. Replacement parts for all electrical components are available from Anchorage Tank. The box is equipped with a hasp and latch so it can be locked when one is working on the electrical components in the system.

DRAWING NO. 2
INSTALLATION SCHEMATIC

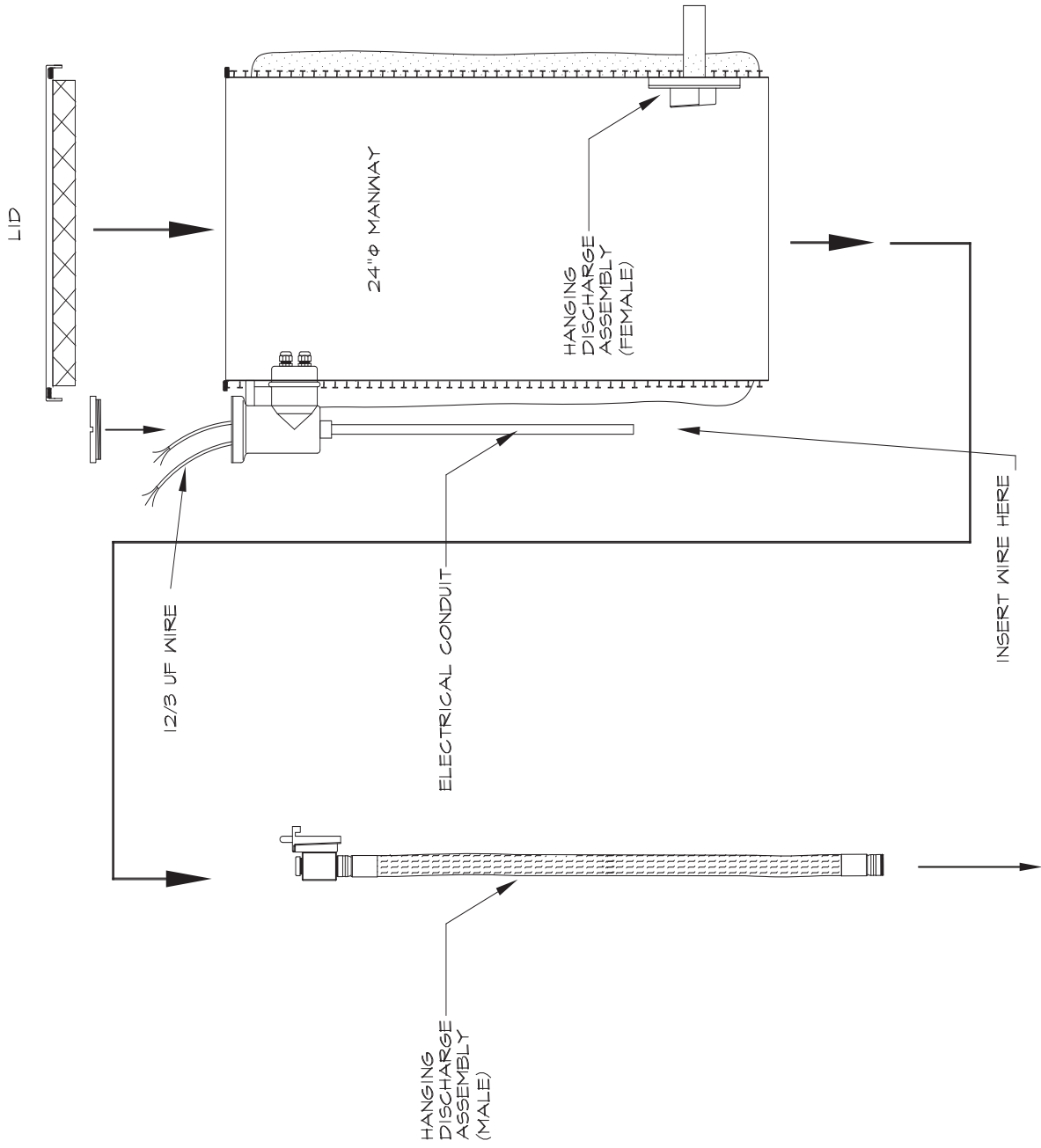

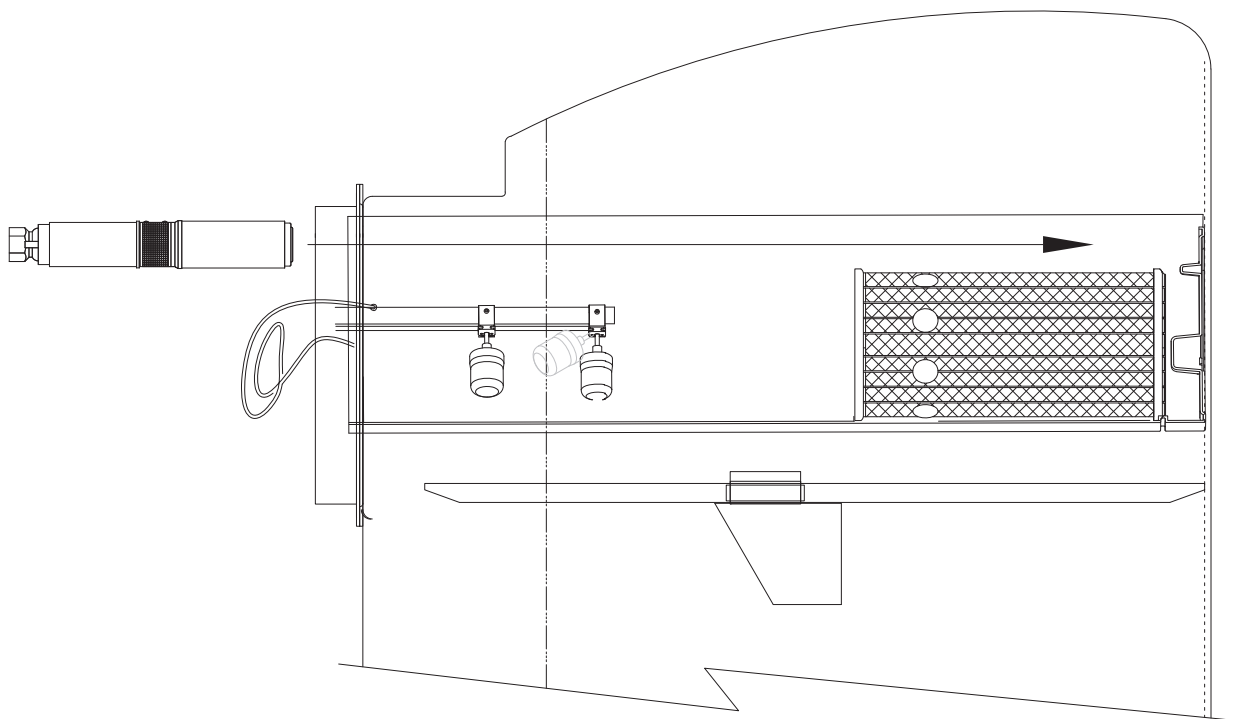

DRAWING NO.3

Assembled 1250 gallon Liftstation tank

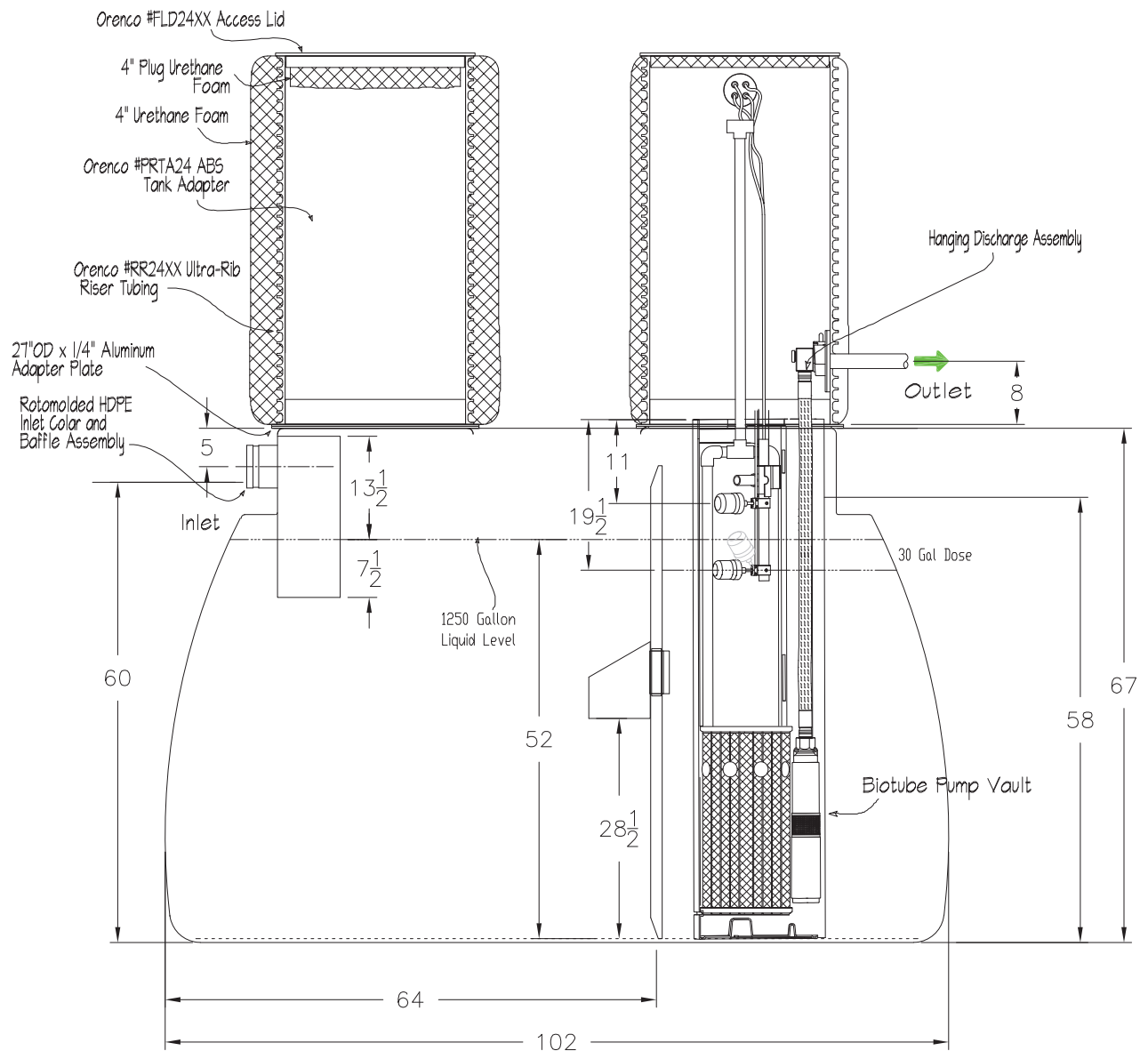

DRAWING NO.4

Assembled 1500 gallon Liftstation tank

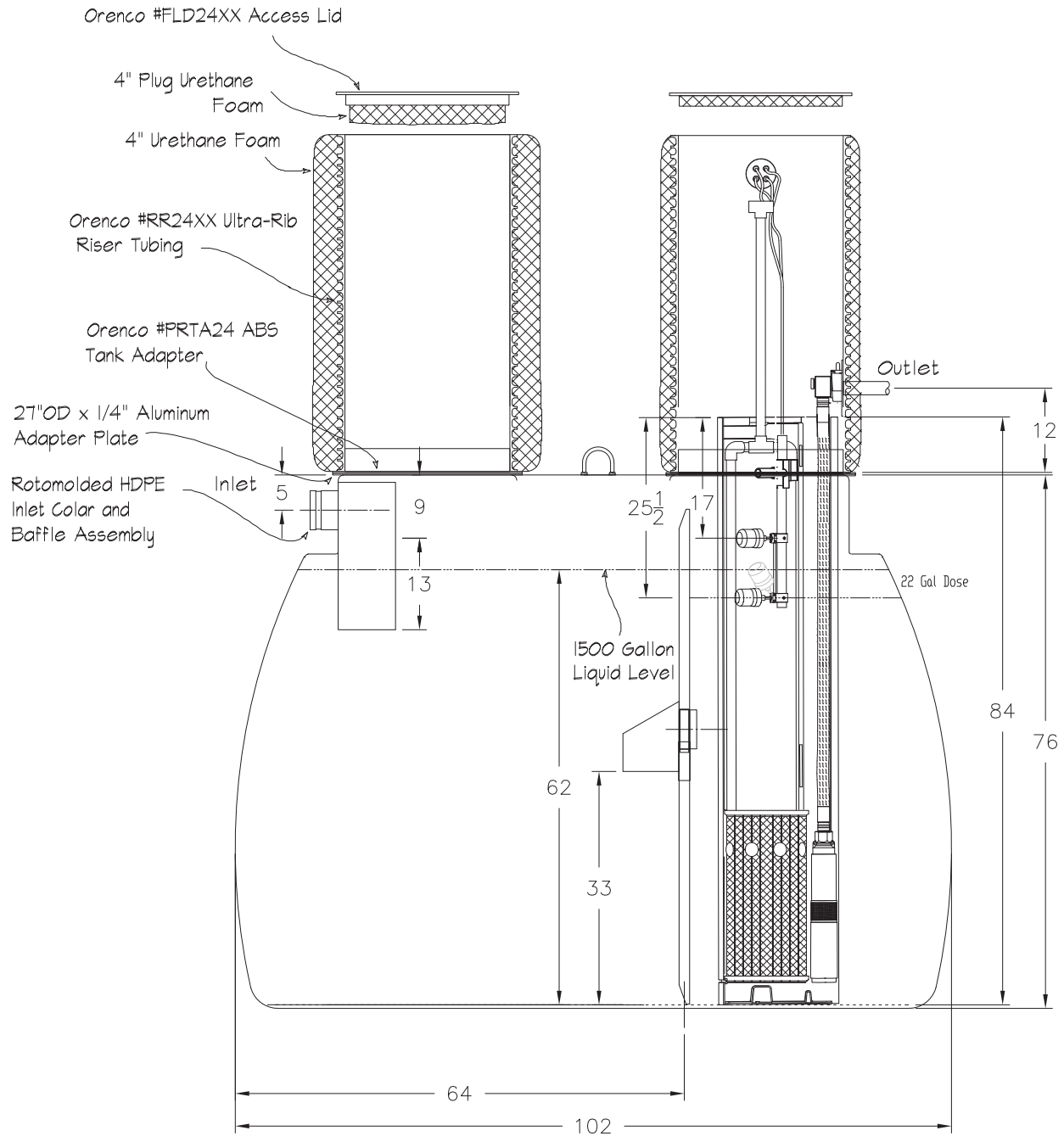

Residential Liftstation Manual

SETTING THE TANK

Excavating the hole and placing the tank are not covered in this manual since these operations must be performed per the instructions of the project engineer and applicable codes and practices. Your tank manufactured by Greer should have been delivered with a document printed on two sides: one side for the tank warranty and the other for Installation Instructions. Your tank is rated for a maximum burial depth of 10 feet.

PREPARING THE RISERS

Since no two installations are the same, all plastic risers are 4 feet tall, insulated, with the external splice box installed.

The riser with 4" insulation is for the inlet end of the tank while the riser with 2" insulation and the external electrical splice box is for the outlet end.

For deeper burial depths, a 6 foot tall riser is available with the top four feet insulated (as shown at the right). Risers may be extended further with a combination of additional splice ring inserts, riser material, and glue.

Determine the desired length of the riser. Be sure to consider what elevation the riser lid needs to be and to allow for the backfill to slope away, usually 6" - 8" above grade.

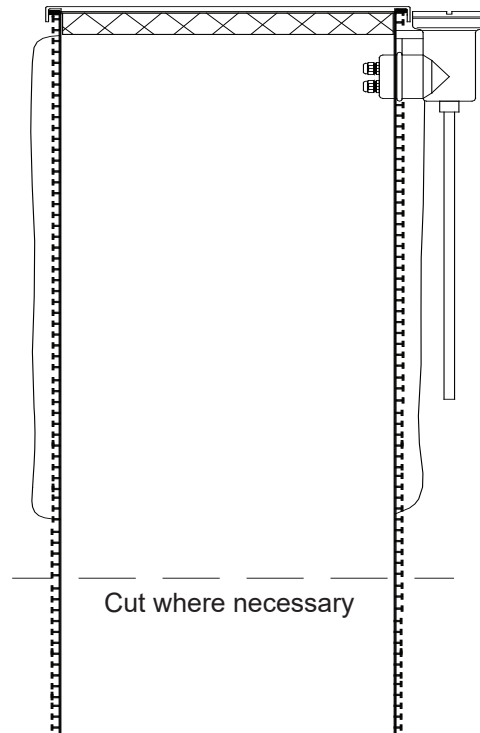

INSTALLING THE HDA STYLE HANGING DISCHARGE ASSEMBLY

Install the mounting plate assembly in the riser before you attach the riser to the tank.

Measure from the tank end (bottom) of the riser and mark the location for the center of the discharge hole on the outside of the riser: **8" for 1250 gallon tanks and 12" for 1500 gallon tanks**

Drill a 2-1/8" diameter discharge hole in the riser, centered on the mark.

Deburr the discharge hole.

Using sandpaper, roughen an 8 inch square area on the inside of the riser around the discharge hole



Measure & mark the location for the center of the discharge hole.

INSTALLING THE HDA STYLE HANGING DISCHARGE ASSEMBLY

and the mounting plate's contact surface.

Apply methacrylate adhesive (from one of the white bags) to the mounting plate. Begin inside at the pipe nipple and work the adhesive into a spiral bead all the way around the edges of the mounting plate.

Press the mounting plate assembly into the discharge hole, with the open end of the female quick-connect pointed towards the lid end of the riser. **Open end Up.**

Use the four stainless steel screws provided to secure the mounting plate assembly at each corner.

Add a bead of methacrylate adhesive around the seam between the mounting plate and the riser, and then make a smooth, continuous fillet around the all four sides. **Make sure there are no voids in the adhesive fillet.**

Complete the riser installation as shown on the next page then you can come back to this.

Using Teflon tape or thread lubricant, screw the threaded end of the discharge hose into the discharge end of the pump.

Once the blue pump vault has been installed in the tank, carefully lower the pump assembly into the vault. Make sure the pump assembly is fully and firmly seated into the female side of the mounting plate assembly.

You'll want to make a one-time purchase of Orenco's HDATOOL for lowering the pump into the tank. Then you'll always have it for future installations and maintenance.

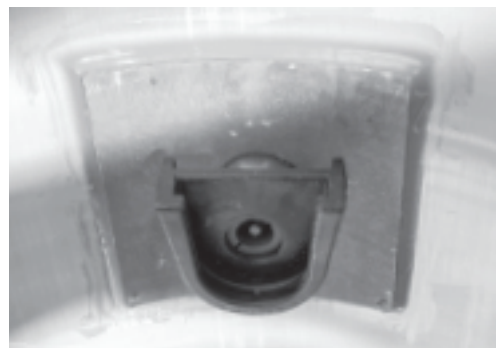
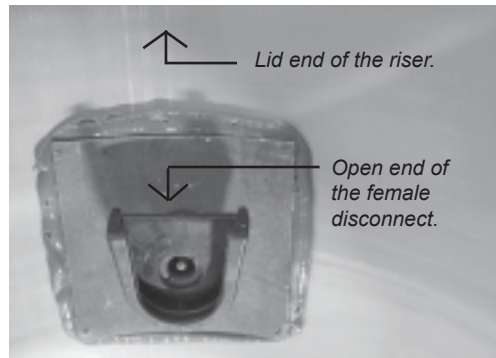

Make a smooth, continuous fillet around the seam between the mounting plate and riser.



Residential Liftstation Manual

INSTALLING THE RISERS

The risers fit on top of each end of the tank. The tank small vertical rings for the risers to slide over

Take a moment to look over the risers to make sure you know which one goes where. The riser with 4" insulation goes over the tank inlet while the other one slides over the outlet end - making sure the hanging discharge assembly will line up with the blue pump vault. If everything looks OK, then it's time to glue.

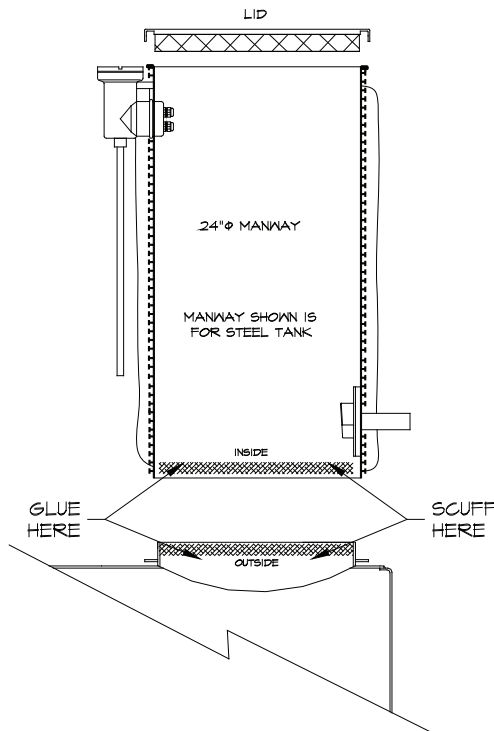

For both tank risers, scuff the exterior surface of the tank and the interior surface of the risers with sandpaper to assist adhesion of the glue.

This stuff stinks! Since you will be outside, ventilation will not be a problem. The bag-o-glue will have two pockets to separate Part A from Part B. Remove the plastic that separates the Parts and squeeze the bag until the adhesive is thoroughly mixed. It will look like cake frosting.

This stuff is temperature sensitive so it will "go off" in about 20 minutes. Be careful not to let the bag freeze. You should also avoid placing the bag on your truck dashboard as the window defroster will cause it to go off in the bag before you can use it.

Carefully cut a corner off the zip-lock bag to squeeze the adhesive out like you were decorating a cake.

Apply a heavy bead of adhesive around the inside edge of the riser first, then squeeze the remainder around the inside of the riser section on the tank.



ROUGH IN WIRING

Remove the top of the junction box (J-box). It spins off the top, like opening a plastic jar.

For residential applications lay 2 pieces of 3 wire, UF (for Underground Feed) conductor (with ground) in the trench between the electrical control box and the tank. (Use 12 GA for runs less than 175' and 10 GA for longer runs.) That's a total of 6 insulated wires and 2 bare grounds. Commercial applications require the wiring to be in conduit. All exposed wiring must be in conduit. There should be a layer of fill over the piping before laying the wire. Mark one of the cables at each end (usually by taping it) for easy identification once the trench is backfilled. Lay two coils of wire at the house and two more at the base of the manhole.

Push both pieces of UF wire up one or both 3/4" conduit on the outside of the manway leaving about 2 feet sticking out of the top of the j-box. Leave the electrician plenty of extra wire on both ends. Seal the conduit at both ends with plenty of silicone caulking.

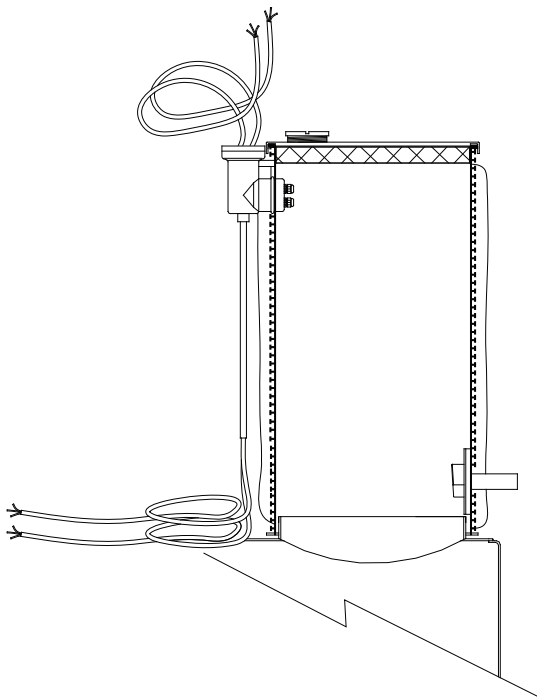

Although not required, it is **highly recommended** that all wiring be placed in a conduit. Experience has shown that wires between the control panel and the riser can go bad. The homeowner will appreciate your ability to snake a new wire through the conduit rather than digging up their new hydro-seeded lawn.

The entire system may now be backfilled. Leave an open area in the trench about 2' out from the foundation for the electrician to install his conduit on the outside of the building. The conduit elbow on the manway should remain above grade.

Residential Liftstation Manual

FINISH PLUMBING

Stop for a moment and orient ourselves, we are now complete with the dirtwork. We are standing on the ground looking down through the 24" diameter manhole into the tank. We are now going to set the pump vault and make up all the plumbing. Consult drawing #2.

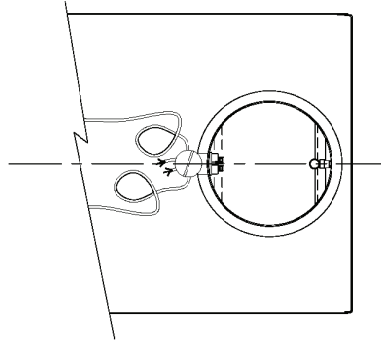

Remove everything but the Biotube and the float assembly from the blue pump vault. Referring to drawing #3, check and, if necessary, set the float levels for your size tank. The distance between the two floats is *not* factory preset so double check to be sure.

If the floats must be field adjusted, refer to drawing #4, and remove the float assembly from the vault. Loosen the set screw in the upper float holder and slide it to its proper location. The measurement is made between the centerline of the 2 cords and is the difference between the on/off float cord and the alarm float cord. Retighten the set screw and reinstall the float assembly in the pump vault.

Now set the bottom float cord at the appropriate distance above the vault floor by loosening the adjustment collar on the float stem holder and moving the pipe with the floats on it as necessary. *Do not alter the floats' tether lengths.* Make sure the floats can swing freely without hanging up on each other or on the screen.

Lower the vault to the tank floor. It will slide between the vault retaining angles in a steel tank. In a fiberglass tank, it will stand on the flat section of the tank floor. Drape the retrieval rope over the j-box. Be sure to bring up the float wires as the vault is lowered. Push the float cords through the cord grips and hand tighten each grip.

Using the Hanging Discharge Tool - this is the pile with a hook on the end of it - carefully lower the pump into the blue pump vault while preventing the pump cord from falling into the tank. There are photos of this installation on Page 11.

If everything lines up, the pump will hang onto the adapter on the riser and the pump will not touch the floor of the vault.

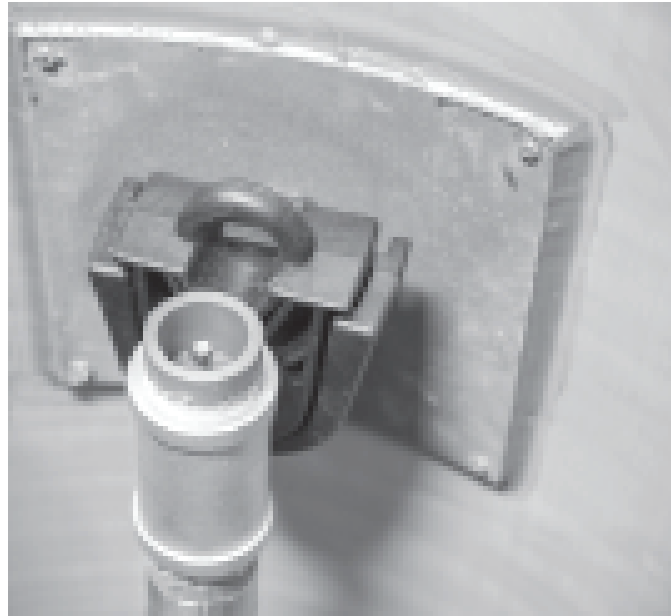

FINISH WIRING

In the City of Anchorage, an electrician must be employed to do the wiring. Outside the city, whether required or not, this is a good idea unless one is thoroughly familiar with wiring and local codes.

A set of wiring instructions are inside the electrical control panel, as well as in this manual. The diagram in the panel should supercede the one in this manual.

This equipment must be installed in compliance with the National Electric Code, as well as state and local codes.



814 AIRWAY AVENUE
SUTHERLIN, OREGON
97475-9012

TELEPHONE:

(541) 458-4449

FACSIMILE:

(541) 452-2884

Simplex Operation

High Level Alarm: This float activates the alarm light and audible alarm when lifted. The audible alarm may be silenced by pressing the illuminated PUSH TO SILENCE button on the front of the control panel. The alarm light will remain on until the float is lowered.

Pump On & Off: This float turns on the pump when lifted and off when lowered.

Key

- = Factory Wire
- - - = Field Wire
- ~ = Alternate Field Wire
- A = Audio Alarm, 115 VAC
- AL = Alarm Light
- AS = Audio Silence Switch
- CCB = Controls Circuit Breaker
- CR = Control Relay
- PCB = Pump Circuit Breaker
- SR = Silence Control Relay

*Options

- CT = Cycle Counter
- ETM = Elapsed Time Meter
- HT = Heater
- PL = Power Light
- PRL = Pump Run Light

Remote Alarm Connections



Note: contact is closed during alarm conditions.

Remote Alarm Connections



Note: 115VAC signal is present during alarm conditions.

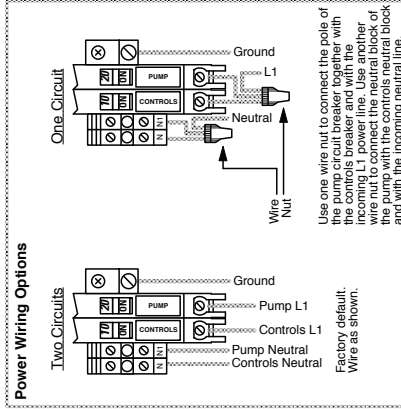

Panel Wiring Diagram Model A1 RA

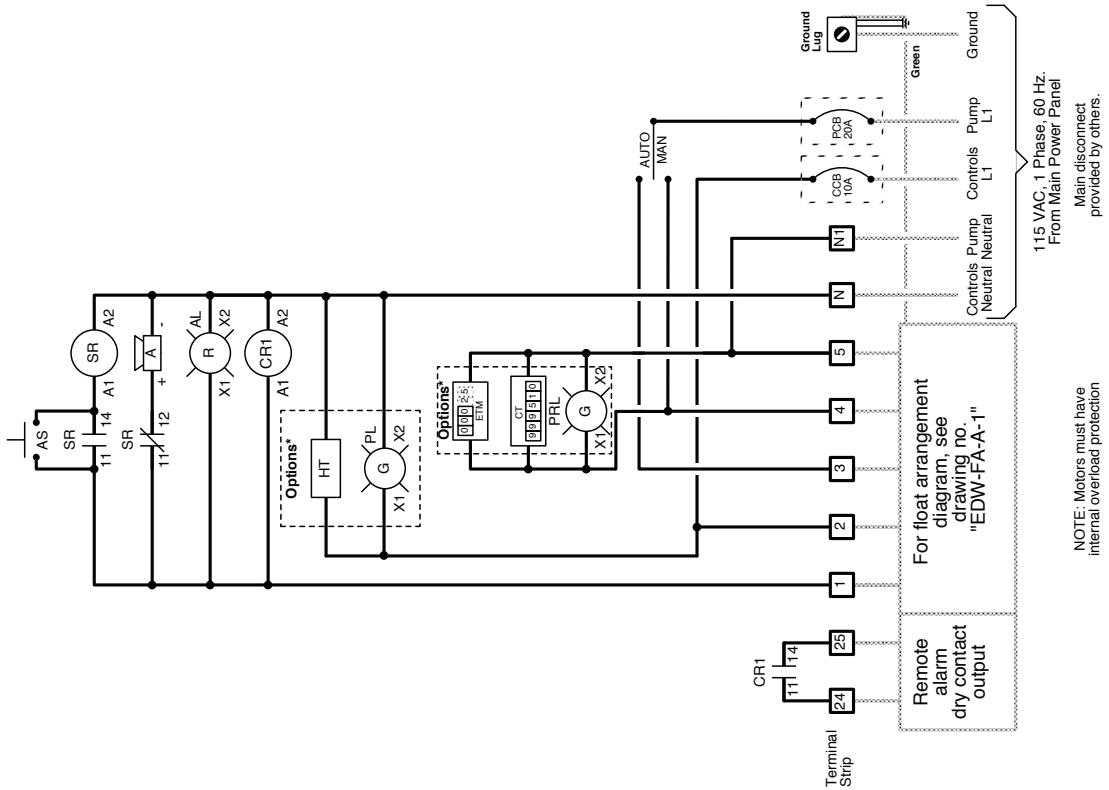

NOTE: Motors must have internal overload protection

Splice Box Wiring Diagram



814 AIRWAY AVENUE
SUTHERLIN, OREGON
97479-9012
TELEPHONE:
(541) 459-4449
FACSIMILE:
(541) 459-2884

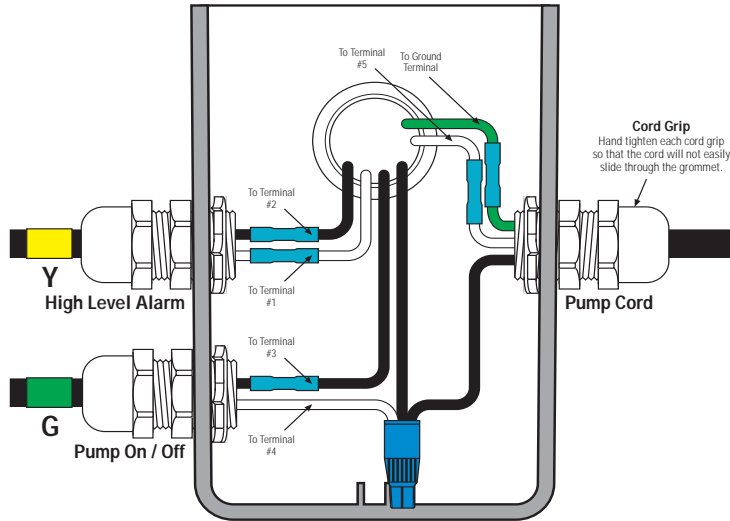

- Key**
- Black Wire
 - White Wire
 - Green Wire
 - Waterproof Wire Nut
 - Heat Shrink & Butt Connector
- * Refer to drawing EIN-SB-SB-1 for splicing instructions.

- Float Tag Colors**
- Y** - Yellow
 - P** - Purple
 - B** - Blue
 - G** - Green
 - R** - Red
 - O** - Orange
 - E** - Grey
 - W** - White

Note: Multi-function floats will have more than one marker
Attention: Failure to follow splicing instructions will void warranty

| Control Panel Series | Float Function Color Code | Splice Box Model | Drawing No. |
|----------------------|---------------------------|------------------|-------------|
| A | YG | SB3 | EDW-SB-A-1 |

EDW-SB-A-1
Rev 1.1 ©04/23/96

Float Arrangement Diagram



814 AIRWAY AVENUE
SUTHERLIN, OREGON
97479-9012

TELEPHONE:
(541) 459-4449

FACSIMILE:
(541) 459-2884

Check the appropriate box for the float function (color code) used in your system.

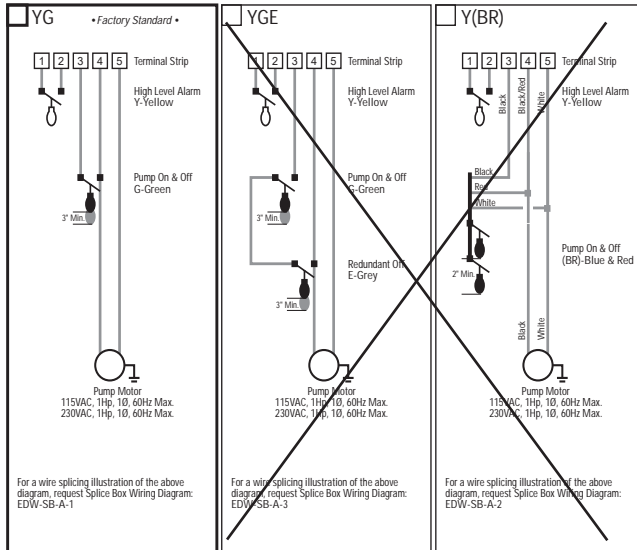

Note: A Floats have been replaced with P Floats

- Float Types**
- Typical OSI float model: A
Specs: contact - normally open differential - 3' min. power rating - signal
Possible substitutions: B,C,D,E
 - Typical OSI float model: E
Specs: contact - normally open differential - 3' min. power rating - signal
Possible substitutions: B,C,D
 - Typical OSI float model: B
Specs: contact - normally open differential - 3' min. power rating - pump
Possible substitutions: C,D
 - Typical OSI float model: R
Specs: contact - normally closed differential - 3' min. power rating - signal
 - Typical OSI float model: K
Specs: contact - normally open differential - 2' min. power rating - pump

| Control Panel Series | Drawing No. |
|----------------------|-------------|
| A | EDW-FA-A-1 |

EDW-FA-A-1
Rev 2.0 ©03/03/98

Panel Installation

Before Installing Panel

1. *Read all instructions before proceeding with the installation. Improper installation may void warranties.*
2. Inspect your order for completeness and inspect each component for shipment damage. If something is missing or damaged, you will need to contact Anchorage Tank to obtain replacements.
3. Wiring diagrams and instructions are also found in the front cover of the panel. Refer to them first as they may be more current than this publication. Check to be sure the instructions and items supplied comply with state and local regulations.
4. A qualified electrician must be employed to install and service the panel and ancillary wiring.

Placement of the Control Panel

5. If possible, install the electrical control panel in view of the tank. The ideal location would be on an exterior wall of the garage. (An exterior location is required by the Municipality of Anchorage.) The control panel is in an explosion proof box and contains a heater, so it can take anything Mother Nature can throw at it. Locate the panel at a convenient height (about 5 feet above the floor) where it will be accessible for maintenance.

Floats and Pumps

6. At this point, the electrical splice box is installed near the top of the riser, the floats are positioned on the float stem, and the pump is inside the flow inducer.
7. Thread the float and pump cords through the cord grips into the PVC splice box, leaving adequate lengths of electrical cord coiled inside the riser to allow for easy removal of the pump and the float assembly. *Do not remove the paper tags or the colored markers from the float cords*, and do not try to thread the tags and markers through the cord grips. These should be left on the float cords, outside the splice box. Tighten the cord grips by hand, not by tool, then check the tightness of the cord grips by tugging on each cord. A cord is secure, and the connection is watertight, when the cord grip is tight enough to prevent slippage. Adequate lengths of cord should be left

8. In the *Rough In Wiring* section, the wires were run from the control panel to the splice box. Conduit that enters the splice box must be sealed with a conduit seal. A conduit seal should be used, even if the wires were direct buried, to prevent the infiltration of water into the splice box.
9. All splices made in the splice box should use waterproof wire nuts or butt connectors and heat shrink tubing. **The splices must be waterproof!** Splices that are not waterproof may cause malfunction of the pump controls if water should leak into the splice box. Refer to the *Splice Box Wiring Diagram* for instructions on how to connect the floats together.

Connect Control Panel

10. Connect wires coming from the floats to the terminals in the control panel. Refer to the appropriate *Float Arrangement Diagram* or *Splice Box Wiring Diagram* for the correct terminal connections.
11. Connect wires coming from the pump to the pump terminals. Refer to the panel wiring diagram for the correct terminal connections.
12. Connect the incoming power to the panel. Power to the panel must be appropriate to the control panel and pump motor (i.e. 120VAC, single phase for a 120VAC motor, 240VAC single phase for a 240VAC motor, etc.) Insure that the panel is properly grounded and that the fuse or breaker wire size, from the main power panel and to the pump, are sized correctly. Separate circuits for the pump controls and each of the pump motors is recommended. Note: voltage for the controls in the panel is always 120VAC, although the pump voltage may be 120VAC or 240VAC.
13. Use 60 degree CU conductors only. Torque the terminal blocks to 7.1 LB-IN. Torque the circuit breaker and ground lugs to 45 LB-IN.
14. When power is applied to the control panel, the wires to the pump may be energized. Do not service the pump or any electrical wiring in the pump vault without disconnecting the power at the circuit breaker and fuse. The pump vault area is a hazardous area, and may contain explosive gases. Take appropriate precautions before working in the pump vault.

SYSTEM STARTUP

1. Recheck the float levels. See Steps 10-12, or the repair and maintenance section.
2. ***Make sure the pump is submerged in water before continuing.***
3. Turn on the main circuit breaker or the switch which powers the control panel. This is usually in a box on the outside of the house or a circuit breaker in the circuit breaker panel within the house.
4. Open the S.T.E.P. system control box and turn on the circuit breaker inside.
5. Flip the steel toggle switch in the upper right hand corner to “man”. Check to make sure the pump is running, then position the switch to “auto”. Check the automatic pump operation by raising the bottom float to turn the pump on and lowering it to turn the pump off.
6. Test alarm operation by raising the top float. This will cause both the alarm in the control box (and the remote alarm in the house if so equipped) to beep. While holding the float up, have someone push the lighted button on the door of the panel. The horn will stop but the light will stay on. Lower the float and the light should go Out and the horn will reset. Raising the float again should resound the alarm.
7. ***Put the lid on the tank and be sure it is secured with the self-tapping screws. An unsecured lid or open tank is a safety hazard!***

This completes the operational check of your system. If the tank is empty, it will usually take a few days for it to fill and the system to operate on its own.

OPERATION

Every day operation is automatic, however the normal cautions observed when operating any septic system also apply to this one. Premature plugging of the screen may result from abuse of the system. Such abuse might take the form of a large scale home canning project with concurrent overuse of the garbage disposal. More likely though, it will be excessive inflow resulting from plumbing leaks in or under the house, excessive use of the laundry or more people using the system than it was designed for. Plugging of the screen, however, should be considered a success, not a failure, as the screen serves to protect the drainfield from the damage that solids carryover can cause.

Don't let anyone talk you into "starter kits" or any type of chemical septic tank cleaner or enhancer.

MAINTENANCE

WARNING: Before doing any work on either the wiring to the level control floats and the pump in the vault or on the S.T.E.P. system control panel, pull the isolation fuse, and turn off the circuit breaker. Then switch off the power to the entire system at the main circuit breaker panel. Close and lock the S.T.E.P. system control panel door to prevent inadvertent activation of the system while work is being performed.

The tank.

It is recommended that the tank be checked every year. In the city of Anchorage, it is required that the tank be pumped every 2 years, preferably in the springtime. **Be there.** Make sure the pumper pumps both compartments of the tank. This tank cannot be completely pumped from only one end.

Screened vault, floats, and pump.

While the following procedure may seem involved, it is really quite simple. And it is vital that maintenance is performed. It takes a few minutes and a few dollars to do it, but it takes a few thousand dollars to replace your drainfield or to fix your basement if you don't do it. Be there when the maintenance is performed to make sure it is properly done. Please refer to the pump vault drawing #4. Also refer to the installation schematic. When you call a pumper, ascertain whether he is familiar with the Anchorage Tank/Orengo liftstations, and whether he will clean your screen. Again, *be there*. Some of them won't disassemble and clean the liftstation components unless you are present, and some of them won't do it at all. None of them will replace your basement carpet or leach field.

The screened vault should be serviced when the tank is pumped as follows:

1. String out a garden hose to the tank. Obtain a pair of channel lock pliers, a 3/4" open end or crescent wrench, and a small padlock or other locking device.
2. Remove the manhole cover and pump the tank clean.
3. **Observe the warning at the beginning of this section.**
4. Separate the plumbing at the union and carefully pull the pump and attached piping out of the tank. It is not necessary to disassemble the pipe sections. Pull up the pump using the plumbing; Do not pull on the pump cord. Hose it off into the tank as you withdraw it paying particular attention to the screened pump inlet. Lay the pump on the fiberglass lid or on a piece of visqueen to protect it from sand or dirt.

5. It is not usually necessary to remove the entire vault from the tank. Hose the Biotube filter assembly as you pull it out of the vault, trying not to get any “gunk” into the vault.

6. Reassemble components in reverse order. Before replacing the Biotube in the vault, refer to drawing #4, and the manual section on system startup. Recheck or reset the float levels measuring from the bottom of the vault. Replace vault and pump in the tank.

7. Take a shower.

Alarm.

Now is a good time to recheck the alarm function. See startup procedure. If you have a remote alarm and it is battery powered, replace the battery and test it with the switch on the alarm box.

REPAIRS

WARNING: Before doing any work on either the wiring to the level control floats and the pump in the vault or on the S.T.E.P. system control panel, pull the isolation fuse, and turn off the circuit breaker. Then switch off the power to the entire system at the main circuit breaker panel. Close and lock the S.T.E.P. system control panel door to prevent inadvertent activation of the system while work is being performed.

The first indication of system malfunction is usually the alarm horn and light, activated by the high water alarm float in the tank. **When a high water alarm is present, immediately discontinue major uses of water such as toilets, dishwashing, and laundry, until the cause can be found and the liquid level in the tank can be lowered** Disregard for the alarm will soon cause the tank to overflow and may cause sewage to back up into the house. It also causes an overflow of solid floating matter into the screened vault which fouls the pump inlet screen and prevents the tank from emptying properly. Follow the maintenance procedures for cleaning the vault and screen while making the repair. Following the procedures below sequentially should quickly isolate the problem.

1. When an alarm is present, the first thing to check is always the circuit breakers, switches, and fuses in the system control panel, and the circuit breaker in the main power panel. If the system restarts, observe the operation for continuous tripping of the breaker. If the condition persists, see the trouble shooting guide for isolation of the problem. If any of these are off or the circuit breaker is tripped, the problem may have been found. Remove the tank lid and, with all switches in their “on” or “automatic” positions, make sure the floats are “up”, then ascertain if the pump is now running.
2. If, after checking all the circuit breakers, fuses and switches, there is still no pump action, flip the man-off auto switch to “manual”. If the pump is now activated, the problem is most likely a faulty on/off float. Pump the tank down to the level of the bottom float and turn the manual switch back to auto.

Never operate the system in the “manual” mode unattended. Misuse of the manual mode switch setting can overload the drainfield, can draw solids to the screen, and can pump the tank down to a level which exposes the turbine section of the pump, resulting in turbine and/or motor failure, which is not covered by your warrantee.

3. To confirm a faulty on/off float, go to main circuit breaker panel in the house and deactivate the circuit for the septic system. Call an electrician or make the following tests.

Make a jumper wire from a piece of #12 guage wire. Remove the wires in the control box which are connected to the on/off float and replace them with the jumper. Reactivate the system. If the pump now works, with the man/off/ auto switch at "auto", the problem is in the on/off float. Deactivate the system, remove jumper wire, replace the on/off wires, and proceed to the appropriate repairs for float replacement instructions.

4. If there is no action in the manual position, but the pump can be heard, the problem is most likely a fouled pump or broken plumbing. Shut the system down and have the tank pumped or, if it can be seen, disconnect the plumbing at the union remove the pump. Clear any fouling and return it to the vault. It is not necessary place the pump into the flow inducer which is probably not visible anyway. Don't make up the union. **Getting everyone out of the way**, reactivate the pump. If it squirts a strong stream into the air, shut it off, make up the union and restart the system. If the stream is weak or if water doesn't run at a problem is a faulty or worn out pump. To replace the pump, see the appropriate section of the repair manual. If the pump doesn't draw down the tank in spite of a healthy stream, there is a blockage downstream from the pump. Have the tank pumped and check for broken or frozen plumbing.

Residential Liftstation Manual

INOPERATIVE FLOATS REMOVE & REPLACE

1. **Switch the circuit breaker in the S.T.E.P. system electrical control panel, to its “off” position, then switch off the power to the system at the main power panel. Close and lock the S.T.E.P. system control panel door to prevent inadvertent activation of the system during repair or maintenance.**
2. Raise the Biotube filter and floats to the top of the manhole.
3. See the maintenance section for this procedure and the installation section for float setting instructions.
4. Unscrew the lid from the external junction box. Remove the float from its holder, loosen the cord grip and appropriate wire nuts, remove the float wires (or remove the wire nuts), and remove the inoperative float from the vault. Replace it with a new float in the reverse order of removal.
5. Re-energize the electrical controls and test the system operation. **Put the lid on the tank and be sure it is secured with the screws. An unsecured lid or open tank is a safety hazard!**

CHECKING ELECTRICAL CONNECTIONS

1. **Switch the circuit breaker in the S.T.E.P. system electrical control panel, to its “off” position, then switch off the power to the system at the main power panel. Close and lock the control panel door to prevent inadvertent activation of the system during repair or maintenance.**
2. Remove the lid from the manway. Remove the lid from the Junction Box. Don't drop the stainless steel screws. Carefully pull the wiring out of the J-Box. Check that each wire is secure. If the J-Box has been submerged, it may have water in it. Remove any liquid, dry thoroughly, and carefully return the wiring to the J-Box and replace its lid. Moisture inside the J-Box can cause voltage to short circuit the floats and a low voltage (24 volts) will cause the buzzer to project a weak sound. **Replace the lid on the tank and be sure it is secured with the screws. An unsecured lid or open tank is a safety hazard!**
3. **Before working in the S.T.E.P. system control panel, recheck the circuit breaker at the main circuit breaker panel. Close and lock the main circuit breaker panel or otherwise make sure that no one can reactivate the main breaker or switch while work is performed in the control box.** Obtain the proper size screwdriver. Carefully tug on each wire going to the tank. Correct any improperly made connections. Reactivate and retest the system.

PUMP REMOVE & REPLACE

1. **Switch the circuit breaker in the S.T.E.P. system electrical control panel, to its "off" position, then switch off the power to the system at the main power panel. Close and lock the control panel door to prevent inadvertent activation of the system during repair or maintenance.**
2. Remove the manhole cover. Separate the plumbing at the union and carefully pull the pump and attached piping out of the tank. It is not necessary to disassemble the pipe sections. Pull the pump using the plumbing, not the pump cord. Lay the pump on the fiberglass lid or on a piece of visqueen to protect it from sand or dirt.
3. Unscrew the lid from the external junction box. Carefully remove wiring out of the j-box. Disconnect the wire nuts. Remove the pump from the plastic plumbing and replace it with a new one in the reverse order of removal. **Replace the lid on the tank and be sure it is secured with the screws. An unsecured lid or open tank is a safety hazard!**

FINDING UNWANTED WATER SOURCES

Unwanted water sources are detailed below:

1. The most common source of excess water in the system is plumbing leaks in the house, usually from running toilets or dripping faucets. This water can usually be seen or heard running into the tank when the cap is removed from the pumpout at the inlet. If water can still be heard dripping into the tank, after shutting off the house water supply completely and draining the pressure tank (if appropriate), it is probably a poor seal at the manhole(s) or broken inlet plumbing. Excavation is usually the only cure.
2. To determine if drainfield feedback is the problem, observe and time the flow of water returning to the tank through the drainback hole in the outlet elbow, immediately after the pumping cycle. Unless the drainfield is a very long distance from the tank, drainback time should not be more than a few minutes. If the drainback seems excessive, the actual distance from the tank to drainfield, the size of the pipe in this run, and the vertical elevation between the tank and drainfield should be determined. From these three items, the quantity of water in the pipe, and the time it should take to return can be estimated. Drainfield siphoning can be indicative of field failure or groundwater entering through breaks in the line to the drainfield. The problem can usually be eliminated only by excavating.

S.T.E.P. SYSTEM HOMEOWNER OPERATION

While the physical and biological processes of handling and treating the wastewater in a S.T.E.P. system occurs automatically, it is important that homeowners exercise discretion in their disposal of waste to the system. As a rule of thumb, it is recommended that nothing be disposed of in the S.T.E.P. tank - with the exception of toilet paper and mild detergents - that hasn't first been ingested. Avoid dumping toxic chemicals, grease, water softener backwash, and septic tank additives into your system. Also, the use of a garbage disposal in the kitchen sink is not recommended.

Daily use of water should be kept within a reasonable range. Most households use an average of 50 gallons of water per person per day. Excessive water usage can be detrimental to the S.T.E.P. tank and the final disposal area (the drainfield). Excessive water usage will usually result in periodic short alarm occurrences (approx. 2 - 3 minutes long). These short-term alarms may be the result of doing too many wash loads in one day, a leaking S.T.E.P. tank (ground water infiltration), a running toilet, improper float or timer settings, or large social gatherings that might overload the system.

The do's and don'ts lists that follow suggest practices that will help to ensure a long life and minimal maintenance for your S.T.E.P. system.

Residential Liftstation Manual

S.T.E.P. SYSTEM HOMEOWNER OPERATION - DO'S & DON'TS



DO feel free to place a bird bath, potted plant, or other decoration on the tank riser lid, as long as it can be readily removed for the sake of maintenance. Landscaping or permanent structures should be planned prior to installation in order to ensure that the integrity of the system is not jeopardized.



DO keep accurate records of maintenance and service calls. The results will be valuable if system problems occur. Make sure whoever inspects your system keeps a complete record and ask for a copy for your records.

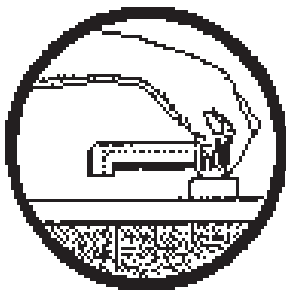

DO practice water conservation. By reducing the amount of water going into your system, you can extend the life of the system and reduce power consumption. Wash clothes and dishes only when you have a full load, and you've heard all this before, right? When possible, avoid running several loads of laundry in one day. Take short showers, avoid turning water fixtures on all the way, and don't let the water run unnecessarily while washing hands, food, teeth, etc.

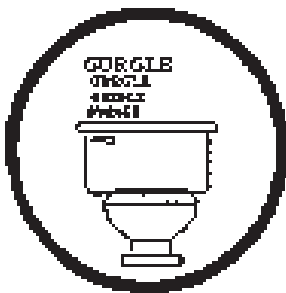

DO be aware that a simple toilet float hang-up can result in over 2,000 gallons of wasted water per day. Normal household usage ranges from 100 gallons to 200 gallons per day. Use water saving devices in the toilet tank, and don't flush unnecessarily.

S.T.E.P. SYSTEM HOMEOWNER OPERATION - DO'S & DON'TS



DON'T accidentally dig up an underground utility with your backhoe. Before you or your excavator digs, telephone the local Underground Locating Services. The number in Anchorage is 278-3121. Just one easy call can provide a free utility locating service that will help you avoid a potential disaster.



DON'T connect rain gutters or storm drains to your septic tank, or allow surface water to drain into it. Your system is designed to process only wastewater from your dwelling.



DON'T use excessive quantities of water. Sure, we are in Alaska with water to spare, but too much water will significantly reduce the performance of your system. Repair leaky toilets and other faucets or plumbing fixtures.



DON'T flush undesirable substances into the S.T.E.P. tank. Flushing flammable and toxic products is downright dangerous, while other materials such as paper towels, rags, newspaper, cigarettes, coffee grounds, egg shells, sanitary napkins, large amounts of hair and cooking grease are a maintenance nuisance. These objects will not biologically "break down" in your tank and will only have to be pumped out.



DON'T dump recreational vehicle (RV) waste into your S.T.E.P. tank because it will increase the amount of solids in the tank, and you'll only have to pump out the tank sooner. Some RV waste may contain chemicals that are toxic and may adversely affect the biological action happening in your tank.



DON'T use the garbage disposer in your kitchen sink as it also increases the amount of solids in your tank. Toss food scraps to the dog or in the trash.

Residential Liftstation Manual

S.T.E.P. SYSTEM HOMEOWNER OPERATION - DO'S & DON'TS



DON'T use special additives or "starter kits" that claim they will enhance the performance in your S.T.E.P. tank. Additives *do not* enhance the tank's performance and can cause major damage to your drainfield. Believe it or not, everything will occur naturally in your system. The naturally occurring organisms will generate their own enzymes for breaking down and digesting nutrients. Sounds gross, doesn't it?



DON'T drive over your tank or sand filter. If they are in an area subject to possible traffic, consider putting up a barricade of shrubs or perhaps a fence.



DON'T enter your tank. The S.T.E.P. system is designed to be serviced from the surface. Not that you would ever be tempted to do enter your tank, but be aware that the gases generated down there and/or lack of oxygen can be fatal.



DON'T dispose water softener backwash in to tank. The backwash brine contains high levels of chlorides that can destroy the microorganisms in the tank.

2020 Edition