



# Residential AdvanTex Treatment Systems

## FAP<sub>2.0</sub>

### The Next Generation of the Fully Assembled Package for Speedy Installations

The AdvanTex® Fully Assembled Package (FAP) consists of an AX20 textile filter pod mounted on a 1500 gallon DCPD composite meander tank with access riser and lid attached. In the tank, an Orenco high-head effluent pumping package is installed in an updated Biotube® pump vault, and all the plumbing and wiring are already connected. The VeriComm® control panel is included. A discharge pump basin and UV Disinfection Unit, if required, may be ordered separately.



#### Save Time, Reduce Errors

Installing the FAP instead of installing components separately saves hours on the site. It also helps to ensure a high-quality installation and reduces costly call-backs. The package is installed in a single excavation and connected to the house sewer and the dispersal system. The unit is light enough to install with a backhoe. Size and Weight: H = 107 in. D = 105 in. Weight = 1,260 lb

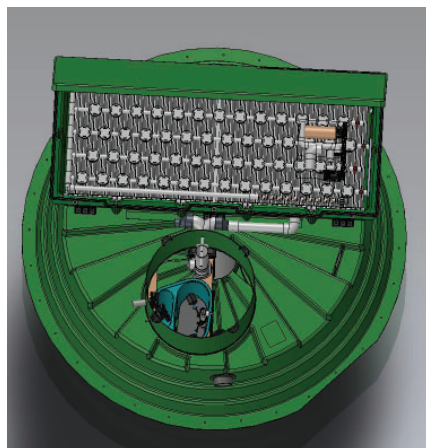

# Submittal Data Sheet

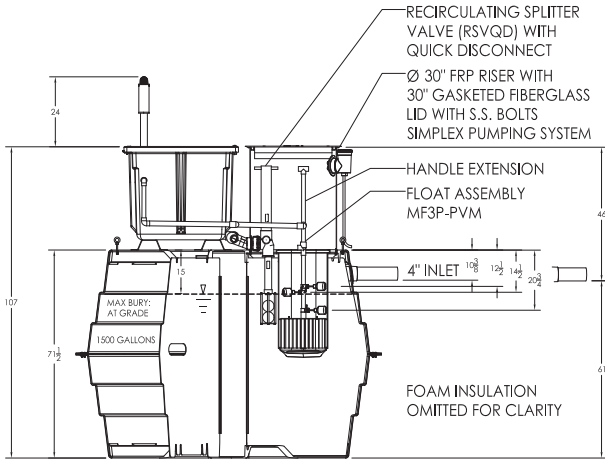

SIDE VIEW

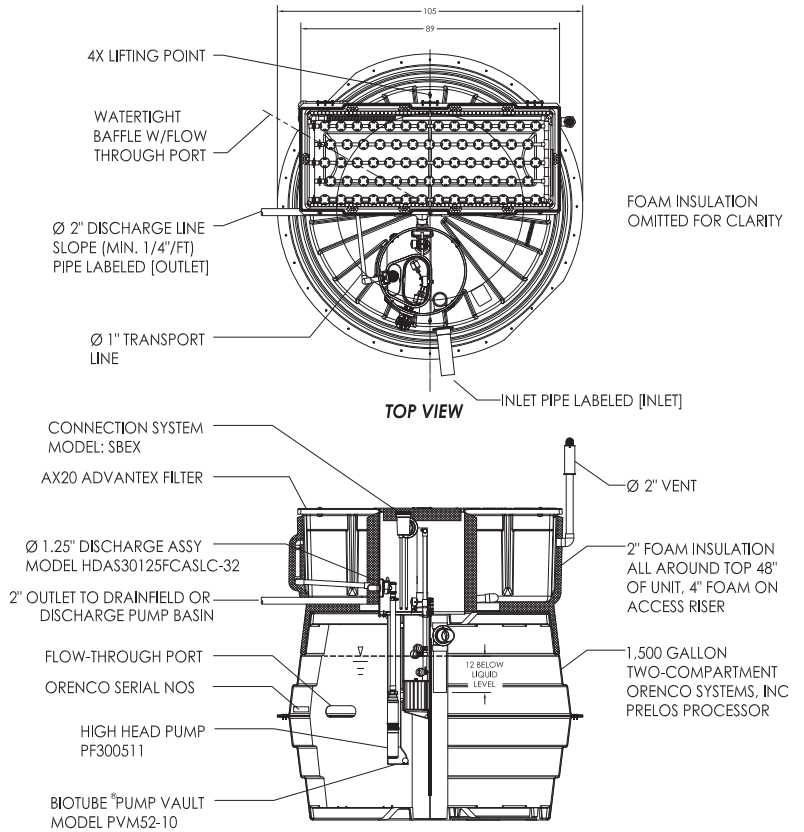

FRONT VIEW

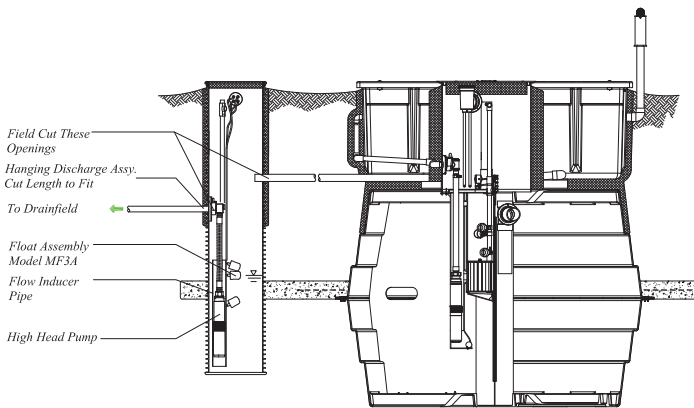

FAP WITH DISCHARGE PUMP BASIN

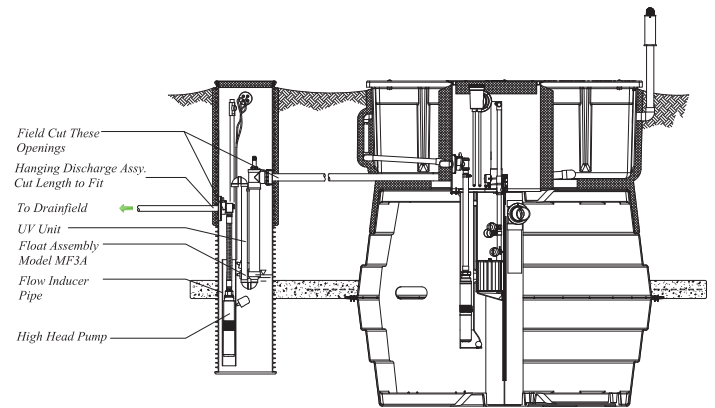

FAP WITH DISCHARGE PUMP BASIN & UV DISINFECTION