

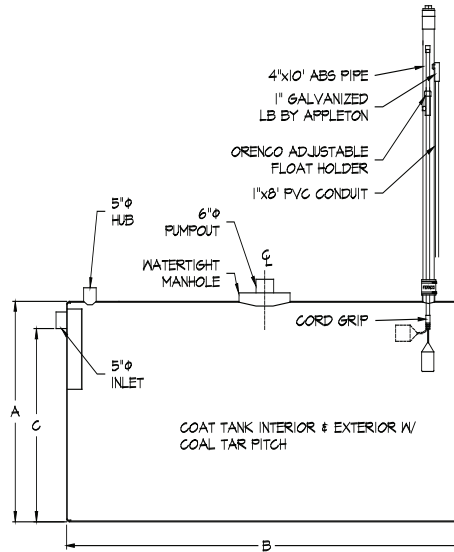

Sewage Holding Tanks



- Constructed to the requirements of the International Plumbing Code.
- Watertight manholes prevent seeping of groundwater.
- Adjustable float levels.
- Orenco Systems®, Inc. Sentinel I (115 volt) or Sentinel II (battery) liquid level alarm.
- Coated inside and out with coal tar pitch.
- Dimensions and weights are approximate.
- Approved by the State of Alaska DEC.

ANCHORAGE TANK MODEL NUMBER	APPROX. GALLONS	STEEL GAUGE	DIAM. (INCHES) (A)	LENGTH (FEET) (B)	INLET INVERT (C)	SHIPPING WEIGHT (LBS)
AT1000H	1,000	12	58	8	51-1/2"	834
AT1500H	1,500	3/16	58	12	51-1/2"	1,409
AT2000H	2,000*	3/16	64	12	57"	1,984
AT2500H	2,500	3/16	64	15	57"	2,672
AT3000H	3,000	3/16	76	13	68-1/2"	2,564
AT4000H	4,000*	3/16	76	17	68-1/2"	3,187