

# B Panel for Pumped Discharge

Successful installation of an AdvanTex Control Panel requires an understanding of all this information.

So, before rolling up your sleeves, please take the time and read through this manual. Reading this manual and maintaining current and accurate records will save everyone time, trouble, and money in the long run.

## Installing the Control Panel

In the Municipality of Anchorage, an electrician must be employed to do the wiring. Outside the city, whether required or not, this is a good idea unless one is thoroughly familiar with wiring and local codes.



**Key Point:**

*The control panel has a distinct identity and has been assigned to the address of that particular job site.*



On the inside of the control panel door, you will find a label that shows the model number and a six-digit RTU number. (RTU stands for Remote Telemetry Unit). The RTU number is the identity of the system for as long as it is in operation. Why is this a big deal to you? Well... if you are installing and taking possession of more than one system at a time, it is easy to simply grab the first panel you find... and it may end up at the wrong house! Anchorage Tank makes the RTU / address assignments as systems are sold so if you get confused - please call Anchorage Tank. This has happened before. Imagine how much fun it is to have a control panel "phone home" with an issue and the Service Provider shows up at the wrong house where nothing is wrong.



## Placement of the Control Panel

There has been a lot of debate where to place the Control Panel. Each site is different but the rule of thumb is that the physical installation of the Control Panel should be within view of the Tank & Filter, at a convenient height, usually 5 feet above grade.

The Control Panel contains motor contactors that make a clunking sound each time the pump is activated. If the Panel is attached to the wall of a house, it sounds like a moose kicking the wall every twenty minutes. With that in mind, it is preferable to mount the Panel on a treated 4x6 post right next to the wall.

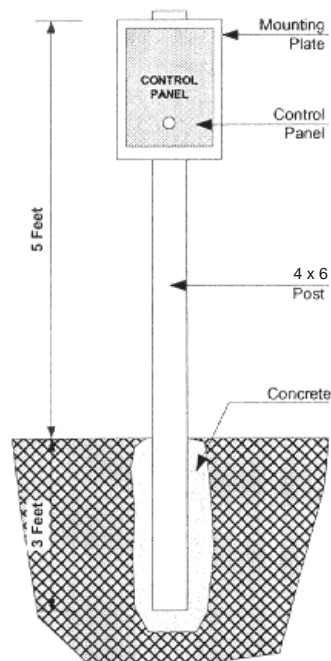

***The Control Panel should NOT be placed inside the home.*** The idea is for the Service Provider to access the panel for maintenance and emergency situations and NOT bother the homeowner.

*Initially it may sound good to have the panel located indoors but it actually isn't. The panel is designed to be located outside.*



**IMPORTANT:**

## Installing the Control Panel



### Key Points:

- Do not remove the colored markers or the paper tags from the float cords. These should be left on the float cord, outside the splice box.
- Do not thread the markers and tags through the cord grips.
- Adequate length of cord should be left within the splice box to allow for easy removal for future disconnecting and re-splicing.
- Wire that is improperly sized (too small) can cause excessive voltage drop, poor pump performance, and premature failure.
- Splices that are not waterproof will cause malfunction of the pump controls if water should leak into the splice box. We've seen it happen.

## Floats and Pumps

At this point, the floats and pump is in place and their wires have been stabbed into the splice box.

Just in case they aren't, thread the float and pump cords through the cord grips into the PVC splice box, leaving adequate length of electrical cord coiled inside the riser to allow easy removal of the pump and float assembly. Tighten the cord grips by hand and then check the tightness by tugging on each cord.

The wires from the Control Panel to the splice box should be run in conduit. **A conduit seal should be used to prevent infiltration of water into the splice box.** The number of wires depends upon the number of pumps and floats, but most 3-float 1-pump systems use 2 runs of 3-wire 12 GA direct-burial. That gives you a total of 6 wires and two bare grounds.

All splices made in the splice box should use waterproof wire nuts or butt connectors and heat shrink tubing.

## HANDY HINT

At the home's electrical panel, you will use two 20 amp breakers, one for the control side of the panel and the other for the pump side.



### IMPORTANT:

**Don't forget the remote alarm.** This connects to the control panel using phone wire and is normally placed inside the garage. The remote alarm is a code requirement.

## Connecting to the Control Panel

Connect the wires coming from the floats to the terminals in the Control Panel. Refer to the appropriate *Float & Splice Box Wiring Diagram* for the correct terminal locations for your system.

Connect the wire coming from your pump to the pump terminal. The Panel Wiring Diagram will display the correct terminal connections for your system.

Connect the incoming power to the panel. Power to the panel must be appropriate to the Control Panel and pump motor e.g., 120 VAC, single phase for a 120 VAC motor, 240 VAC single phase for a 240 VAC motor, etc.)

Ensure that the panel is properly grounded and that the fuse or breaker and wire size, from the main power panel to the pump, are correctly sized. A separate circuit for the pump controls and each of the pump motors is recommended.

**Note: Voltage for the controls in the panel is always 120 VAC, although the pump voltage may be 120 VAC or 240 VAC.**

Use 600 CU conductors only. Torque to the following: Terminal blocks @ 15 LB-IN. Circuit breaker @ 20 LB-IN and ground lugs @ 45 LB-IN.

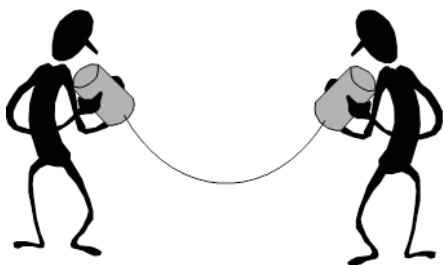

### Key Points:

Do not service the pump or any electrical wiring in the pump vault without disconnecting the power at the circuit breaker and/or fuse.

Serious injury and/or damage to the system could result if the panel is not properly grounded. Ensure that the fuse, breaker, and wire size, from the main power panel and to the pump, are sized correctly.

The pump vault is a hazardous area and may contain explosive gases. Take appropriate precautions according to local, state, and federal regulations before commencing work in the pump vault.

It is the responsibility of the installer to comply with all local, state, and federal regulations that may govern the installation of systems of this nature. Failure to comply with such regulations may void the manufacturer's warranty and could possibly cause bodily injury.

## Connecting for Remote Monitoring

To permit remote monitoring of the system, the VeriComm Control Panels have the option to utilize a common phone line or a high speed internet connection. You will need to check with the homeowner to determine which connection method is available or desired.

**Should they decide on a regular phone line, please be aware these panels do not need a dedicated phone line, merely an extension of an existing line.**

Installation of a traditional copper-wire analog telephone line is straight-forward. You'll notice a phone jack connection in the middle of the control panel. A DSL line filter/surge arrestor is also installed. Once you have a dial tone at the end of this phone line, just plug it in and you're good to go.

**Digital connections (internet) will require an ethernet cable run from the House Internet Router out to the control panel to connect to the Lantronics equipment mounted on the inside of the control panel door.**

Control Panel Wiring Diagram

### Control Panel Wiring Diagram AdvanTex® Treatment Systems Model VCOM-AX20B1 RA IP

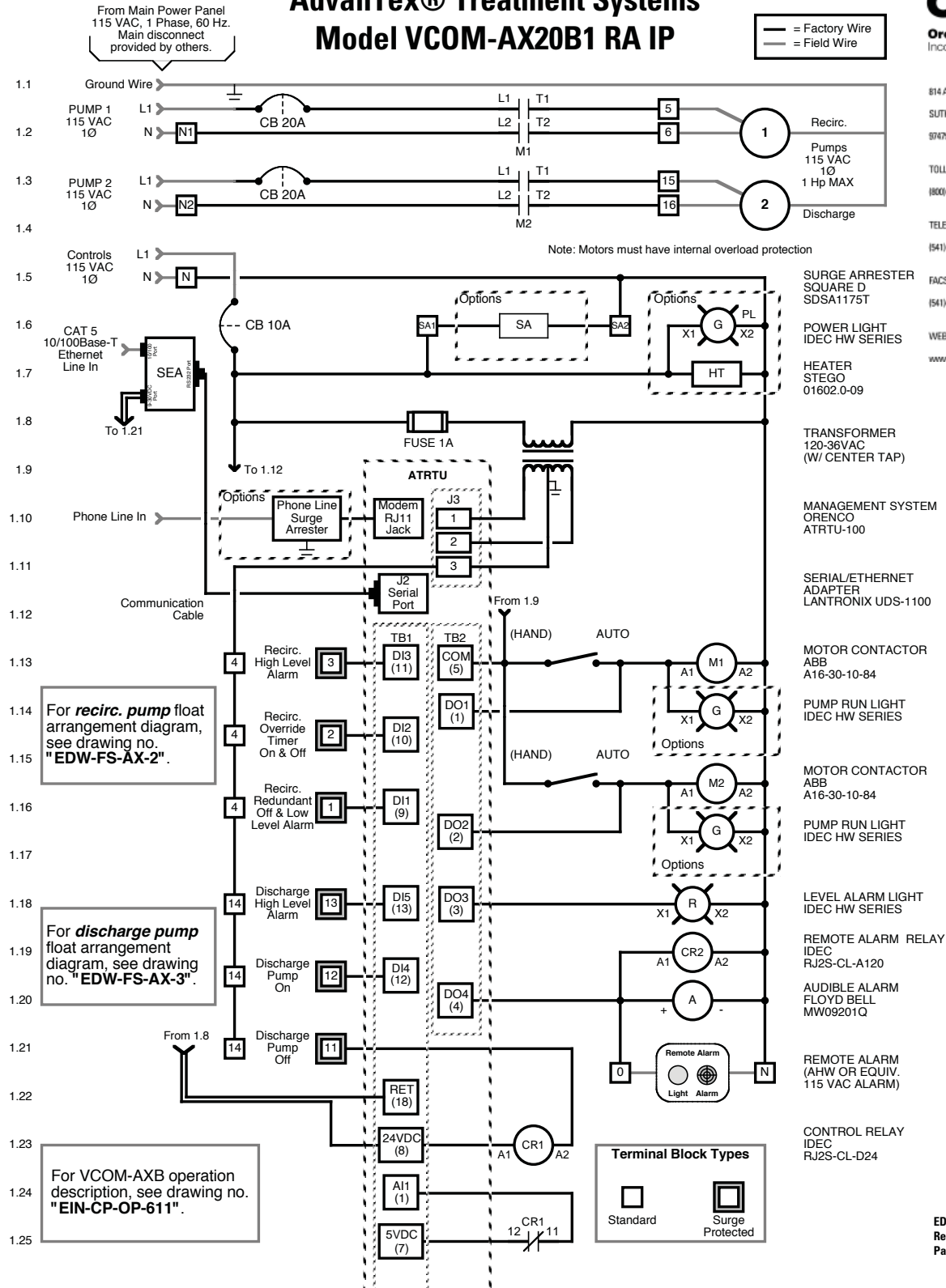

814 AIRWAY AVENUE  
 SUTHERLIN, OREGON  
 97479  
 TOLL FREE:  
 (800) 348-9843  
 TELEPHONE:  
 (541) 459-4449  
 FACSIMILE:  
 (541) 459-2884  
 WEB SITE:  
 www.oreco.com

EDW-WD-AX-119  
 Rev. 8.0 © 06/24/13  
 Page 1 of 2



**Control Panel Wiring Diagram**

2.1  
2.2  
2.3  
2.4  
2.5  
2.6  
2.7  
2.8  
2.9  
2.10  
2.11  
2.12  
2.13  
2.14  
2.15  
2.16  
2.17  
2.18  
2.19  
2.20  
2.21  
2.22

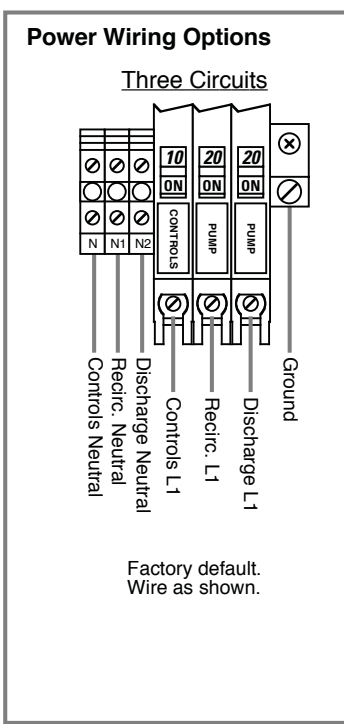
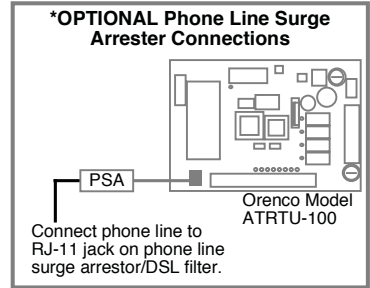
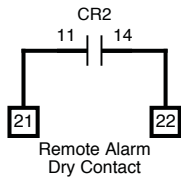
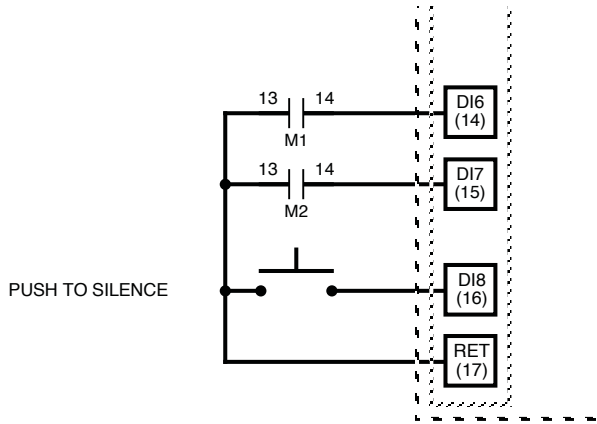

Installations in existing construction may pose issues in providing power to the septic panel. A suggestion is to install a sub panel, like they do for a hot tub installation.

Float & Splice Box Wiring Diagrams for Septic Tank Recirculation



814 AIRWAY AVENUE  
SUTHERLIN, OREGON  
97479-9072  
TELEPHONE:  
(541) 459-4449  
FACSIMILE:  
(541) 459-2884

# Float & Splice Box Wiring Diagram

For use in two pump systems, recirc. side.

### Float Arrangement

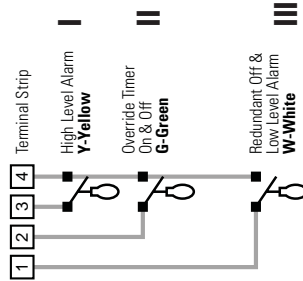

### Float Types

Typical Orengo float mode: A  
Specs: contact - normally open  
differential - no minimum  
power rating - signal

### Splice Box Wiring

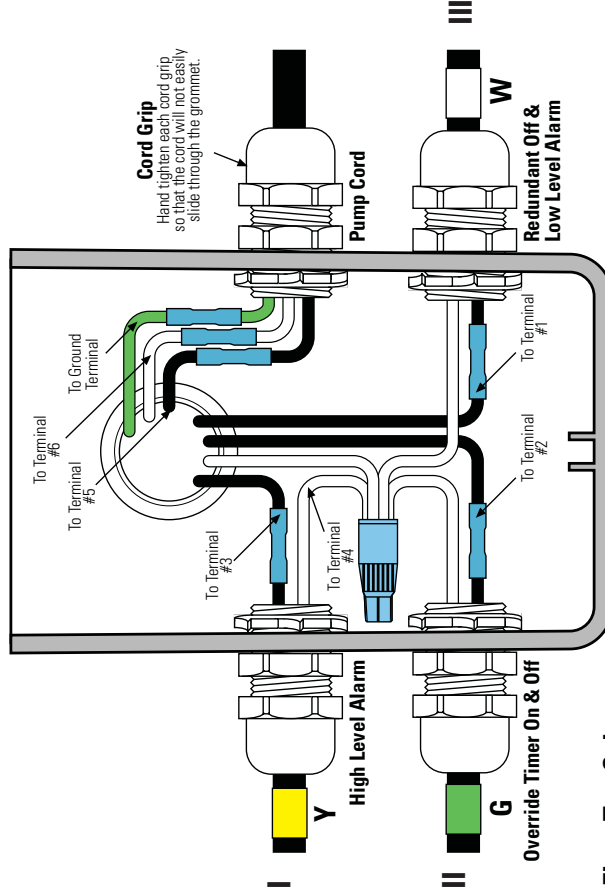

### Float Tag Colors

- I Y - Yellow R - Red
- P - Purple O - Orange
- B - Blue E - Grey
- II G - Green W - White
- III

Note: Multi-function floats will have more than one marker

### Key

- Black Wire
- White Wire
- Green Wire
- Waterproof Wire Nut
- Heat Shrink & Butt Connector \*

Attention: Failure to follow splicing instructions will void warranty

\* Refer to drawing EIN-SB-SB-1 for splicing instructions.



### IMPORTANT:

Contrary to what this diagram shows, Orengo no longer color codes their float wires. Because of this, you will want to mark the yellow float cords yourself with a black Sharpie pen. For example: place a tick mark I for Yellow, II for Green, and III for White.

Control Panel Series	Splice Box Model	Drawing No.
VCOM-AXB	SB4	EDW-FS-AX-2
Float Function Color Code		
YGW/		

Float & Splice Box Wiring Diagrams for Discharge Pump Basin



**Oreco Systems**  
Incorporated

814 AIRWAY AVENUE

SUTHERLIN, OREGON

97779-9012

TELEPHONE:

(541) 459-4449

FACSIMILE:

(541) 459-2884

# Float & Splice Box Wiring Diagram

For use in two pump systems, discharge side.

## Float Arrangement

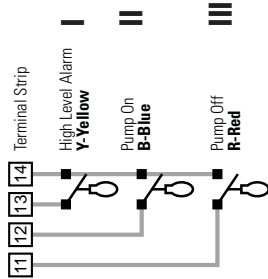

## Float Types

Typical Oreco float model: A  
Specs: contact - normally open  
differential - no minimum  
power rating - signal

## Splice Box Wiring

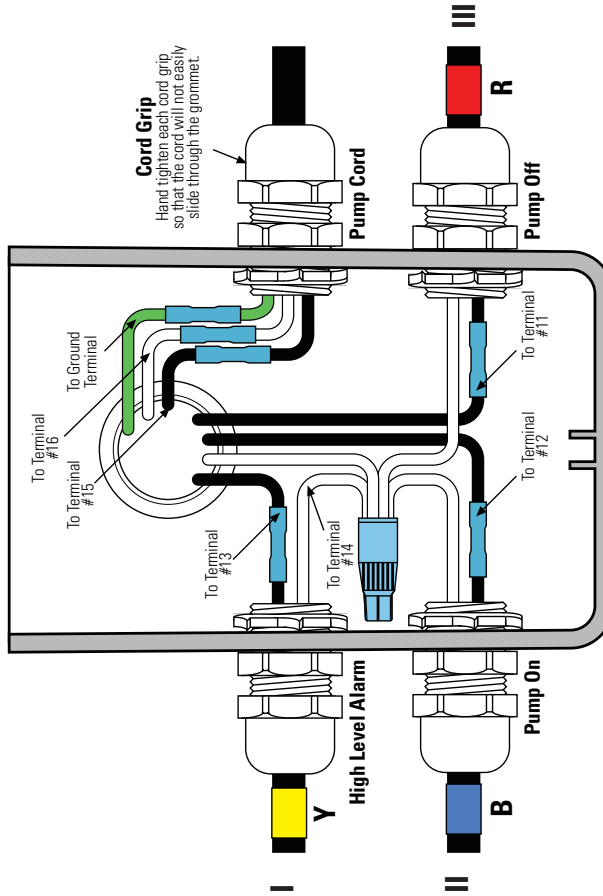

**Cord Grip**  
Hand tighten each cord grip so that the cord will not easily slide through the grommet.

## Key

- Black Wire
- White Wire
- Green Wire
- Waterproof Wire Nut
- Heat Shrink & Butt Connector\*

## Float Tag Colors

- I Y - Yellow R - Red III
- P - Purple O - Orange
- II B - Blue E - Grey W - White
- G - Green

Note: Multi-function floats will have more than one marker

**Attention:** Failure to follow splicing instructions will void warranty

\* Refer to drawing EIN-SB-SB-1 for splicing instructions.

Control Panel Series

**VCOM-AXB**

Float Function Color Code

**/YBR**

Splice Box Model

**SB4**

Drawing No.

**EDW-FS-AX-3**

EDW-FS-AX-3  
Rev 1.0 ©08/10/01



**IMPORTANT:**

Contrary to what this diagram shows, Oreco no longer color codes their float wires. Because of this, you will want to mark the yellow float cords yourself with a black Sharpie pen. For example: place a tick mark I for Yellow, II for Blue, and III for Red.



**The Discharge Pump Basin - Control Panel Operation**



**What's so special about this gray box?**

The VCOM-AXB telemetry-enabled panel is used for remote monitoring and control of the dual pumping operations of a timed recirculating pump (in the Tank) and an on-demand discharge pump (in the Discharge Basin).



Basic control logic manages the day-to-day functionality of the Control Panel. The VCOM-AXB system continually recirculates influent; until the Recirculating Splitter Valve (RSV) seats, then the system gravity discharges small amounts of treated wastewater throughout the day into the Discharge Basin. During peak flow conditions, more aggressive timer settings (overrides) are used to manage the increased demand. As the Discharge Basin fills with treated effluent, floats activate a discharge pump to a dispersal field.

Fault conditions are automatically reported to the VeriComm Monitoring System (a web-based database by Orenco Systems) and not locally at the panel, making the system virtually invisible to the homeowner. Alarms and Alerts cause an email to be forwarded to Anchorage Tank personnel. However, if these conditions are not responded to, or the system cannot communicate with the VeriComm Monitoring System (the phone line might not be connected), then the local alarms at the Panel will activate.

To silence local alarms, press the "Push to Silence" button until the audible alarm stops.

