

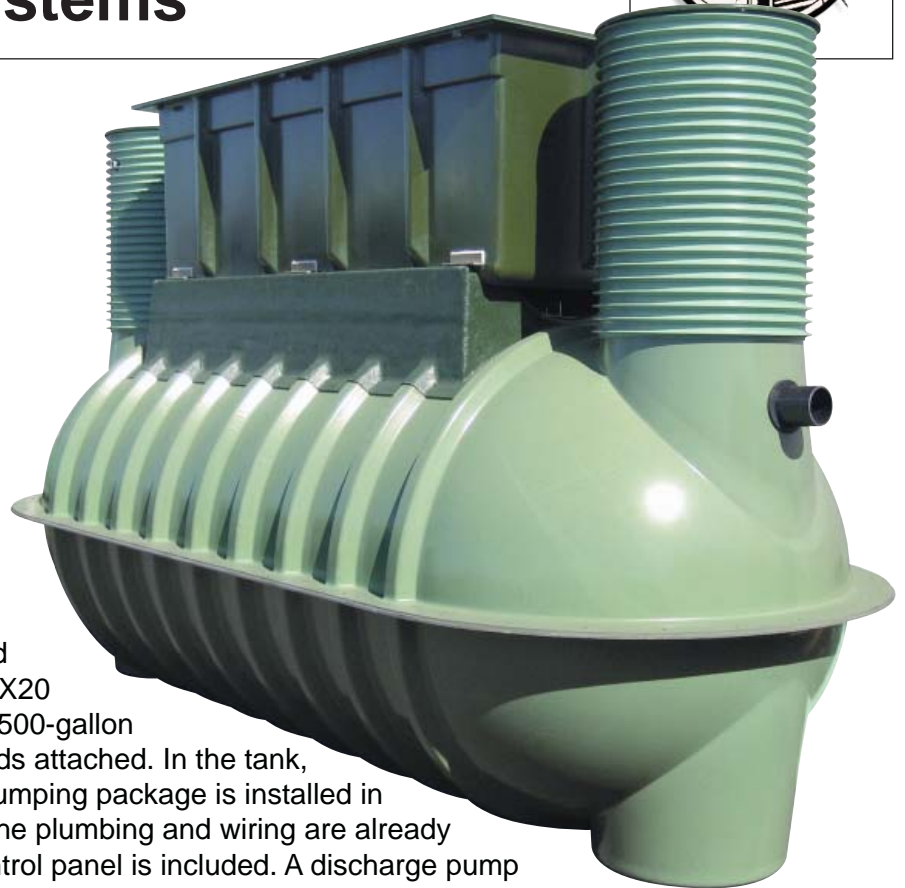

Residential AdvanTex Treatment Systems

FAP

Fully Assembled
Package
for Speedy
Installations



The AdvanTex® Fully Assembled Package (FAP) consists of an AX20 textile filter pod mounted on a 1500-gallon fiberglass tank with risers and lids attached. In the tank, an Orenco high-head effluent pumping package is installed in a Biotube® pump vault, and all the plumbing and wiring are already connected. The VeriComm® control panel is included. A discharge pump basin and UV Disinfection Unit, if required, may be ordered separately.

Save Time, Reduce Errors

Installing the FAP instead of installing components separately saves hours on the site. It also helps to ensure a high-quality installation and reduces costly call-backs. The package is installed in a single excavation and connected to the house sewer and the dispersal system. The unit is light enough to install with a backhoe. Size and Weight: H = 99-1/4 in. L = 168 in. Weight = 1,615 lb



Submittal Data Sheet

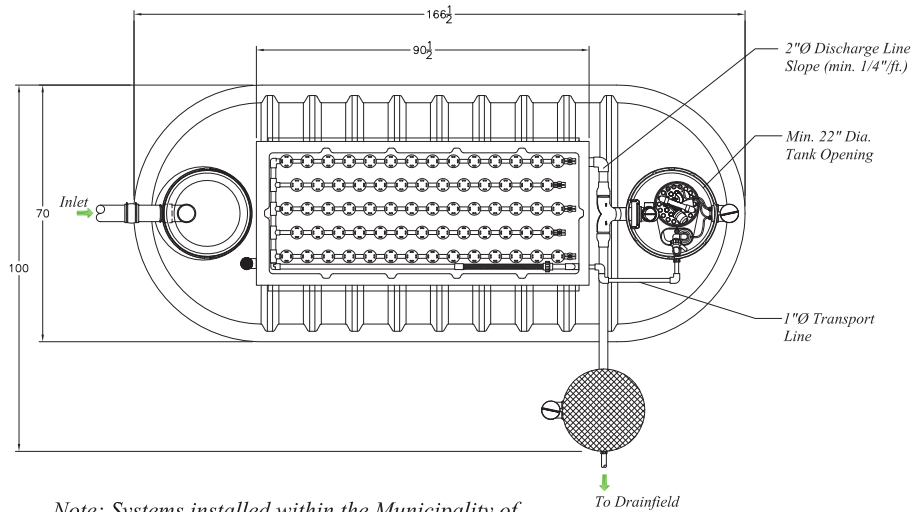

Note: Systems installed within the Municipality of Anchorage must have 2" of spray-on urethane insulation to a depth of 48" below pod lid. The insulation is not shown in this drawing for clarity.

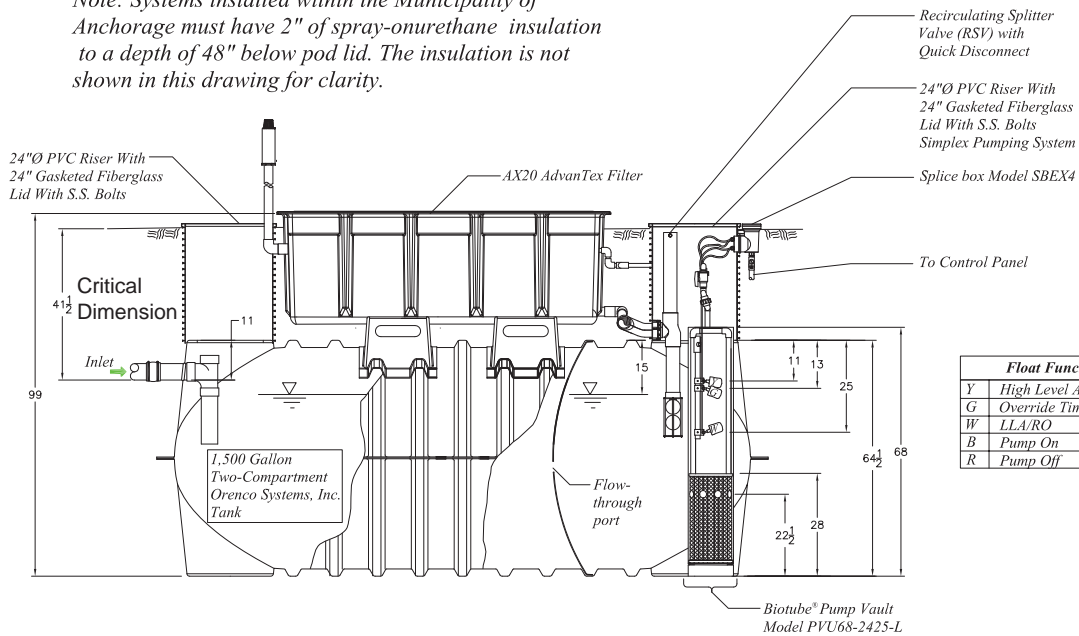

Float Functions	
Y	High Level Alarm
G	Override Timer ON/OFF
W	LLA/RO
B	Pump On
R	Pump Off

